



246 W. Main St.
Leola, PA 17540
(717) 661-7041
www.dallee.com

AUTOMATIC BACK AND FORTH provides a simple means of testing locomotives on a workbench or having action on the layout that does not require an operator. This can be useful in the operation of a trolley line that would otherwise be merely scenery. This action enhances the overall motion that would normally occur during operation and adds to the illusion of activity.

This automation can be accomplished simply, using DALLEE ELECTRONICS components, in any gauge or scale provided DC power is applied to the track and the device operating can respond to polarity reversing. This package provides for a timed stop at each end, in addition to the track polarity being reversed. These types of BACK-N-FORTH operations are available in multiple scenarios. The simplest is found in items 561 to 564. These merely reverse the track power based on a time function and are limited to a total travel time of approximately 2 minutes. If the track or travel time is longer than this you cannot have a stop occur at the ends. Thus you need to sense when you get there which is what this package of components does. The end stop time only starts when you arrive at the end and does not start before that.

The overall operation is as follows: The TRAK-DTT2, when current flow is sensed by a locomotive or trolley reaching the end rail section, will activate its relay for an adjustable time frame and then do nothing further until its time is up. When the relay contacts are wired to remove power from the track, a stop occurs. In simplified terms, when the time frame has elapsed, the relay relaxes restoring track power. If the wires to the end rails are routed through the detection coil of the TRAK-DTT, polarity will be reversed when each end is activated via locomotive or illuminated car entry. This circuit is shown on page 2. The TRAK-DTRL will change the state of its double pole double throw relay every time it senses current flow in an opposite sense coil. In this case the "SET" and "RESET" sense coils. The relay contacts are wired as a polarity reversing switch. The end rail sections are insulated and wired through the detection coils of the TRAK-DTRL as well as the detection coil of the TRAK-DTT2.

Including a timed stop at each end as above assumes that the time frame for each stop is the same. This would be the normal usage. If you should desire to have a different time frame at each end it will be necessary to add another TRAK-DTT2. It is also possible to include intermediate stops at any location provided the distance between stops is adequate to allow a few seconds running time so that the time circuit of the TRAK-DTT2 can reset. If the time frame of the intermediate stop is the same as at the ends the original TRAK-DTT2 can be utilized with additional wiring. The TRAK-DTT2 routes track power before the TRAK-DTRL sensors so that polarity does not reverse during an intermediate stop. The inclusion of the intermediate stop in the circuitry is shown on page 3. If it is desired that the intermediate stops have a different time frame, another TRAK-DTT2 would be needed for each different time frame. Multiple stops can also be accomplished by just gapping the track as shown for the single STOP section.

In one application we have done, on an automated trolley line, there were a total of nine stops, including the end stops. If all stops had been of equal time, the automation could have been accomplished with only one TRAK-DTRL and TRAK-DTT2. The actual installation involved four separate time frames so there were four TRAK-DTT2 units utilized. Thus creating a more realistic effect.

Tips for good operation: Because we are depending on current flow it is important that both the rail and the wheels be kept reasonably clean so that the possibility of faulty sensing is minimized. It is also necessary that the track length between the ends be long enough that there will be at least a few seconds running time to allow the circuitry to reset itself so that further detection can be made.

By utilizing the TRAK-DTRL, we eliminated the possibility of double reversing at the ends, so it is impossible to have any trolley run off the ends unless you have reversed the tracks power. So it is important to have the tracks power supply / throttle kept in the proper direction. Upon first powering up, set the trolley in the middle of the track. Then apply track power. The trolley needs to traverse towards the "SET" sense end first (the right end of the drawing). If you are not, reverse the polarity of the power pack. Thereafter the power packs reverse should not be needed. If you are using a fixed DC source to operate the trolley, or you know the polarity of the DC Track Power, then connect the "+" wire to the Red wire and the "-" to the dark brown wire (if this is a G gauge train, then you have to reverse this since their standard is opposite of the NMRA). Then your polarity will be correct for operation. The TRAK-DTRL is wired to provide a fixed polarity to the track upon each sense coils detection. It will not reverse like the TRAK-DTL.

The main problem with any automation is the lack of adequate power from some power packs, you need at least 20VA of power. If you have inadequate power, your trolley will travel improperly. A suggestion to cure this problem is to either run the 12VPS (electronics) on one power pack and run the trolley on another. Another solution is to use Item #690 or #990 to power the electronics.

AUTOMATIC REVERSE with TIMED STOP AT ENDS with reverse memory.

Standard wiring practices:

All wires crossing each other only connect when a DOT / CIRCLE is shown. Dashes & other line patterns are used to clarify different wires used.

all Back-N-Forth operations:

require DC (polarity reverse) track operation. are best to start running in the middle. require a few seconds (5 or better) of time from leaving one stop location and arriving at the next stop location! long lengths of track between locations does not affect the operation, very short lengths that transverse in a short time are not recommended.

install stranded wires by stripping insulation back 3/16", place wire in hole, run screw down to clamp in position. Make sure wires do not short to adjacent terminals!

GAP - a "GAP" (cut rail to provide an air joiners, wood is not recommended) is placed on one rail as shown to form the "SIGNALLED SECTION". In this case the "SIGNALLED SECTION" is the section labeled "STOP & REVERSE" and also "STOP".

The time adjust should be set to approx. 10 O'Clock (a few seconds) or more.

If "G" gauge, reverse the "+" and "-" of the TRACK POWER's DC (Not that of the 12VPS).

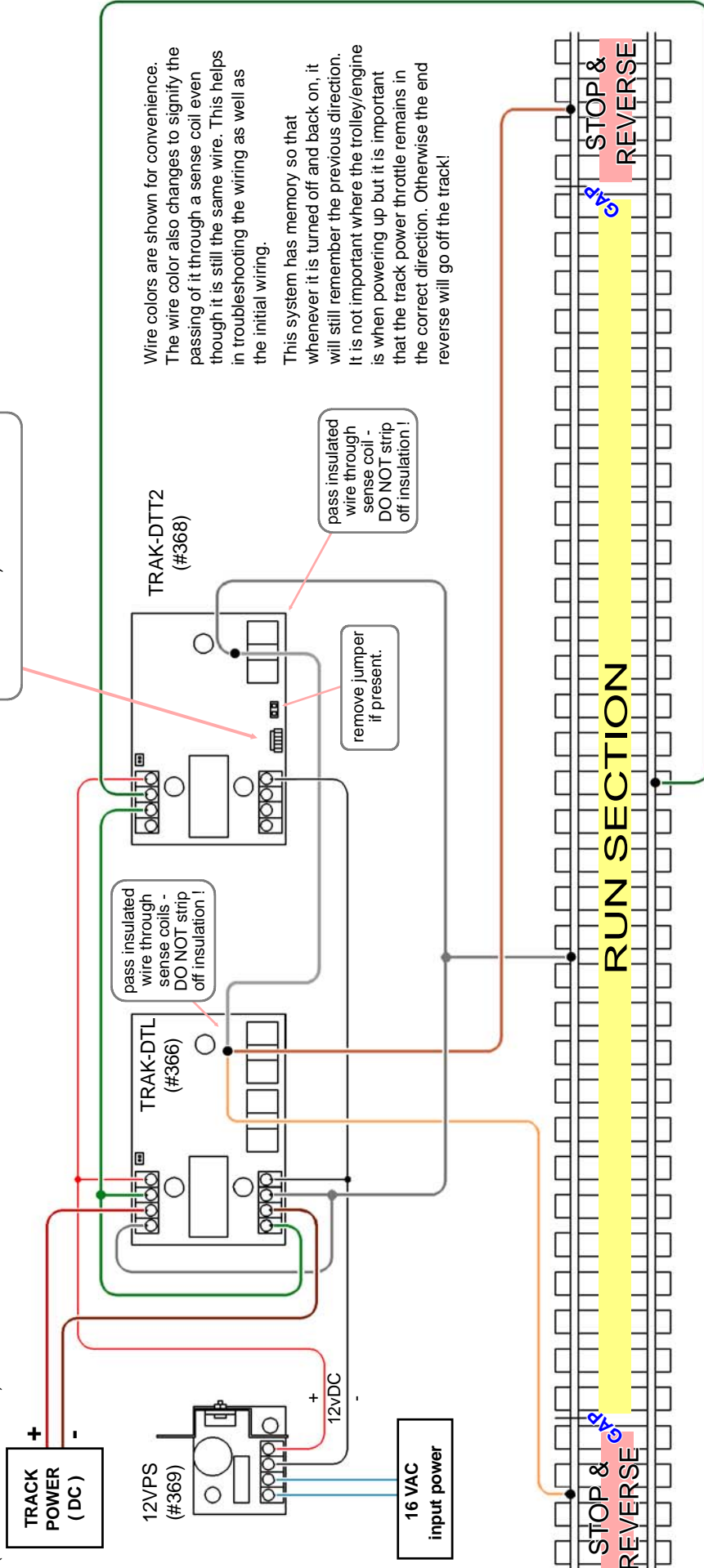

Wire colors are shown for convenience. The wire color also changes to signify the passing of it through a sense coil even though it is still the same wire. This helps in troubleshooting the wiring as well as the initial wiring. This system has memory so that whenever it is turned off and back on, it will still remember the previous direction. It is not important where the trolley/engine is when powering up but it is important that the track power throttle remains in the correct direction. Otherwise the end reverse will go off the track!

246 W. Main St.
Leola, PA. 17540
(717) 661-7041
www.dallee.com



AUTOMATIC REVERSE with TIMED STOP AT ENDS & BETWEEN with reverse memory.

Standard wiring practices:

All wires crossing each other only connect when a DOT / CIRCLE is shown. Dashes & other line patterns are used to clarify different wires used.

all Back-N-Forth operations:

require DC (polarity reverse) track operation. are best to start running in the middle. require a few seconds (5 or better) of time from leaving one stop location and arriving at the next stop location!
long lengths of track between locations does not affect the operation, very short lengths that transverse in a short time are not recommended.

If "G" gauge, reverse the "+" and "-" of the TRACK POWER's DC (Not that of the 12VPS).

install stranded wires by stripping insulation back 3/16", place wire in hole, run screw down to clamp in position. Make sure wires do not short to adjacent terminals!

The time adjust should be set to approx. 10 O'Clock (a few seconds) or more.

GAP - a "GAP" (cut rail to provide an air "GAP" or use insulated plastic rail joiners, wood is not recommended) is placed on one rail as shown to form the "SIGNALLED SECTION". In this case the "SIGNALLED SECTION" is the section labeled "STOP & REVERSE" and also "STOP".

The center "STOP" section has the same timing as the end stops. More than one can be made by simply duplicating the wiring to this stop. If different timing is required, another Trak-DTT2 is needed.

Wire colors are shown for convenience. The wire color also changes to signify the passing of it through a sense coil even though it is still the same wire. This helps in troubleshooting the wiring as well as the initial wiring.

This system has memory so that whenever it is turned off and back on, it will still remember the previous direction. It is not important where the trolley/engine is when powering up but it is important that the track power throttle remains in the correct direction. Otherwise the end reverse will go off the track!

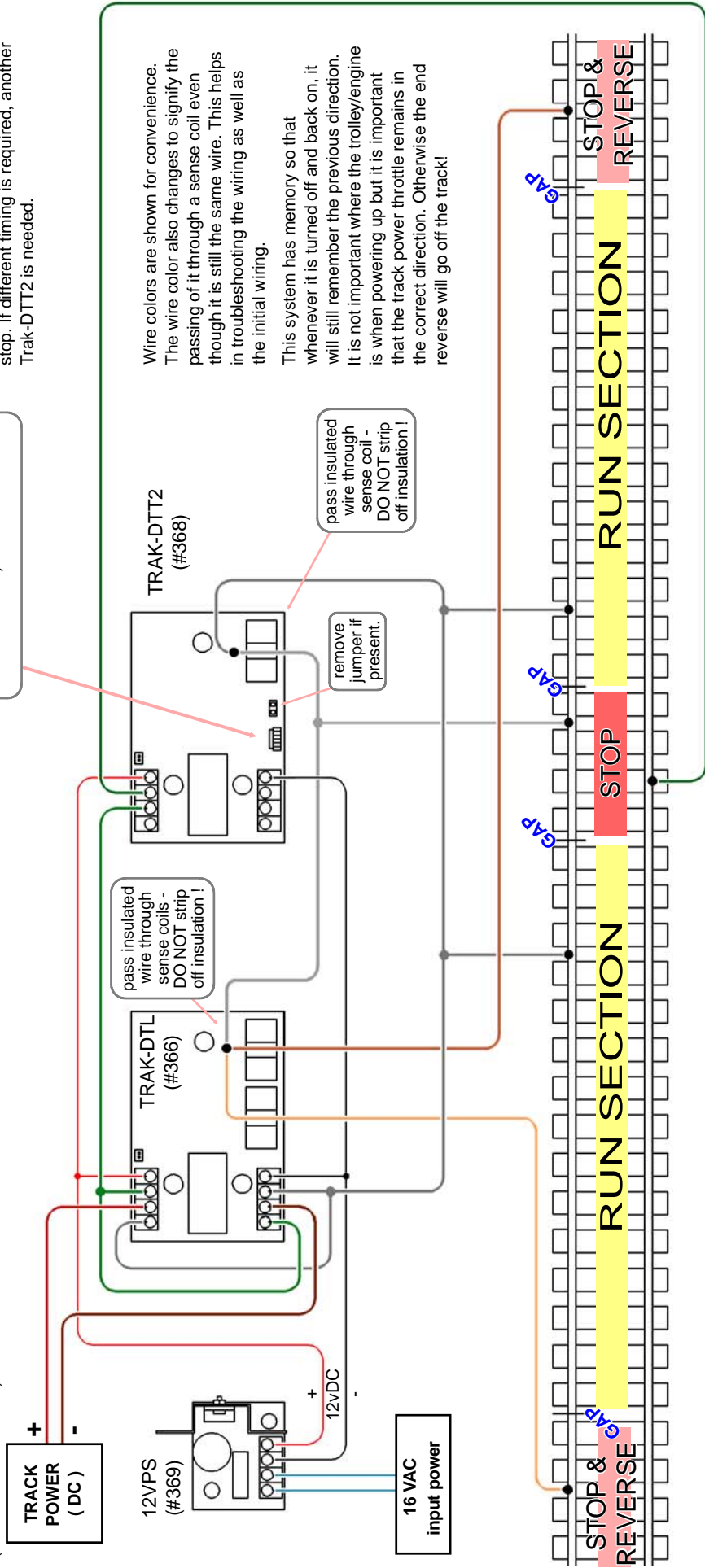

246 W. Main St.
Leola, PA. 17540
(717) 661-7041
www.dallee.com

DALLEE
ELECTRONICS, Inc.