

11 Watt Amplifier

with true Treble & Bass controls!

This amplifier was designed to be used with all Dallee Electronics Inc. sound systems and may also be adapted to other systems. Item #671

The amplifier includes both Treble and Bass controls and is designed for use with 8 ohm, or higher, speakers. Do not use 4 ohm speakers or multiple speaker configurations equivalent to less than 8 ohms! The amplifier is small enough to fit most 'S' gauge and larger type trains.

Excess heat can be generated when volume is set to high levels or with Bass set to boost so when installing this amplifier be sure to allow for adequate ventilation and do not place the board too close to plastic body shells. Note: cutting Treble rather than boosting Bass results in a bass effect with less heat being generated.

Standard round speakers are usually rated for 1/2 watt or less and are not appropriate for use with this amplifier. Use of heavier wattage speakers, as available from Dallee Electronics, are recommended.

The maximum DC input is 25 volts. Typical operation is in the 12 to 24 volt range. If insufficient voltage is present, the amplifier will not turn on, i.e. pass any sound to the speaker. Output power is limited to that of the supply power.

Inadequate supply power will hamper the amplifiers ability to perform the audio output power desired. This unit will also shut down (turn off) if it gets too hot. Adequate cooling must be provided if this is a problem.



246 W. Main St.
Leola, PA 17540
(717) 661-7041
www.dallee.com

Input power connections are to be connected to the DC source specified observing proper polarity. The input power is not protected from reverse power to allow for the highest audio output with a low DC input voltage. None of the speaker connections, nor any other connection or part of the board, should come in contact with any other connection or metal body part. Improper connections will destroy the unit and void all warranty.

Refer to the sound system that you are using and follow the installation instructions.

General installation:

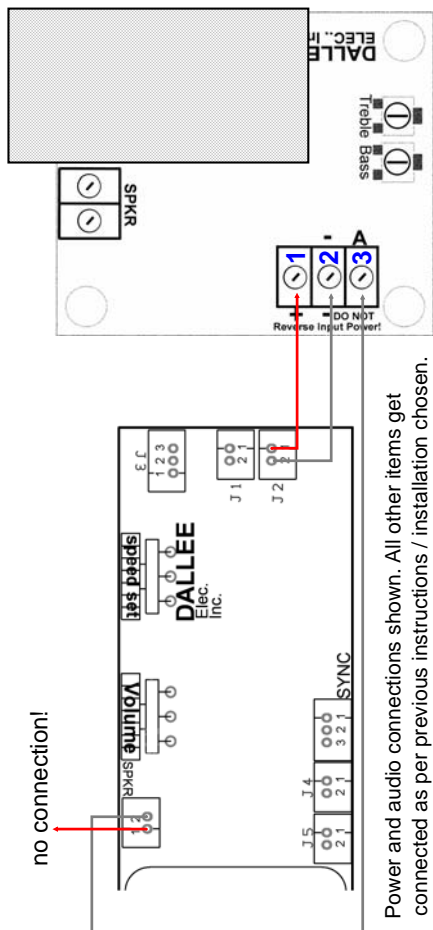
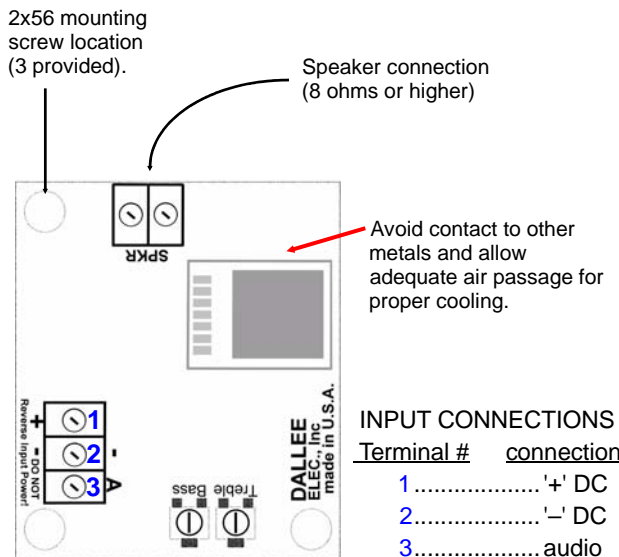

Remote volume control with Auxillary Amplifier

With single sound systems, connect the gray wire from the speaker output to input "1". Connect the rest as shown.

If using two sound systems, connect the junction of the two sound systems 1k resistors (shown on the backside) to the "+" side of the capacitor (labeled ⊕), then merely add the potentiometer as shown.

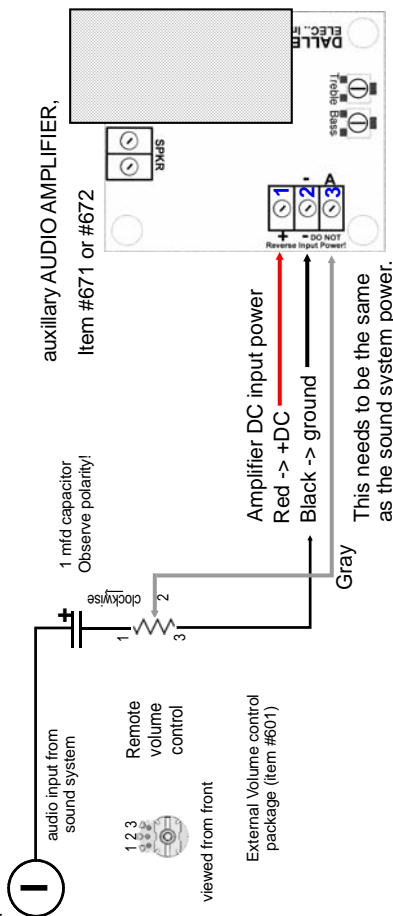

Auxiliary Amplifier connections with two speakers.

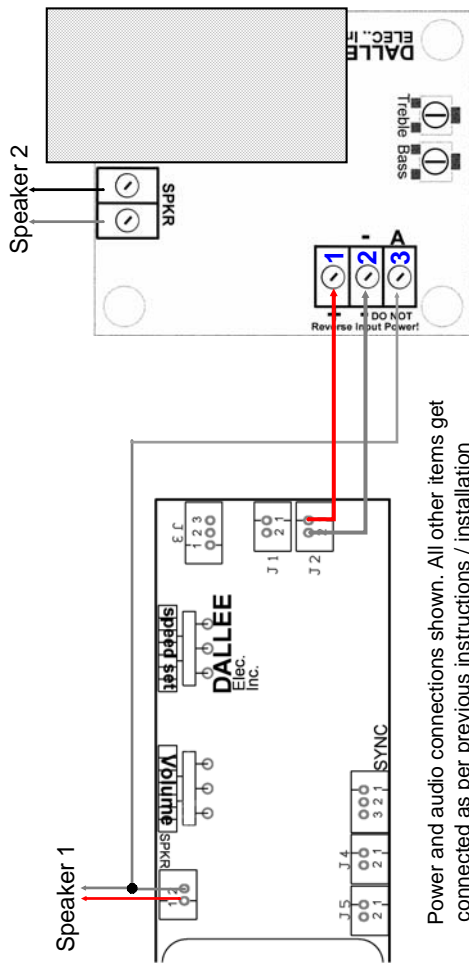

Power and audio connections shown. All other items get connected as per previous instructions / installation chosen. Remember, the audio amplifier's require at least 12 volts to operate with a 24 volt maximum limit.

Using with DCC or other fixed voltage track power system and Dallee Electronics DC Sound System.

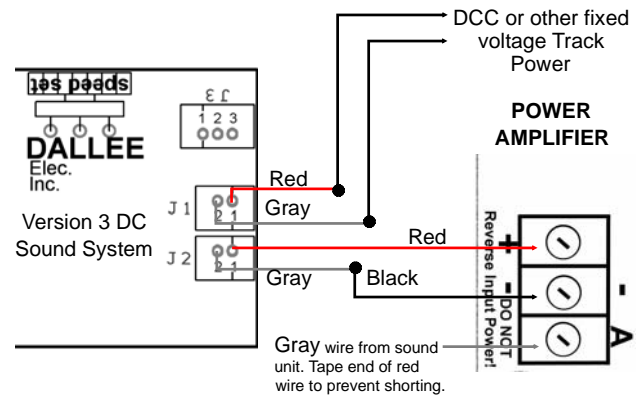

When using a single Dallee Sound system, wire the DCC track power as shown (pins 5 & 6). Wire the DC output terminals (pins 3 & 4) to the amplifier. Do NOT get the polarity reversed to the amplifier! That would destroy it and is not covered under any warranty!

All functions, motor inputs, audio input get wired as before, shown in the sound systems instructions.

When using a dual system, only wire one of the sound system to the track power (J1) input. Wire the other sound system to operate from the DC (J2) power as shown for the amplifier above.

If 60 Hz track power is present, extra filtering of the DC power (from J2) is required. Use a 6800mfd or higher value capacitor with at least a 25 volt rating.

Using two or more sound systems with 1 amplifier

By placing a 1k resistor in series with each sound systems output and then tying them together a mono channel can be obtained for utilizing a single amplifier. This drawing is shown to the right.

When using DCC or other AC type input, DC power for the amplifier can be obtained from one of the sound systems as shown. The other sound system can be powered from the DCC or AC source as well as the same DC source used to power the sound system. The top sound system has to be powered in order for this common power method to work. You may also provide for more DC filtering, if needed, by placing a large electrolytic across the DC power.

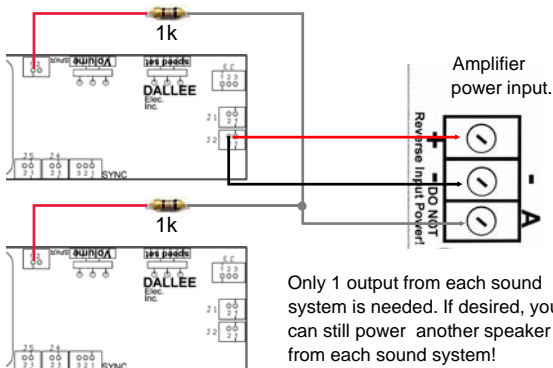

Only 1 output from each sound system is needed. If desired, you can still power another speaker from each sound system!

Utilizing Fixed DC or AC track power to provide the Power Amplifier and DC Sound System power in lieu of batteries in an on board application with receiver operating from track power.

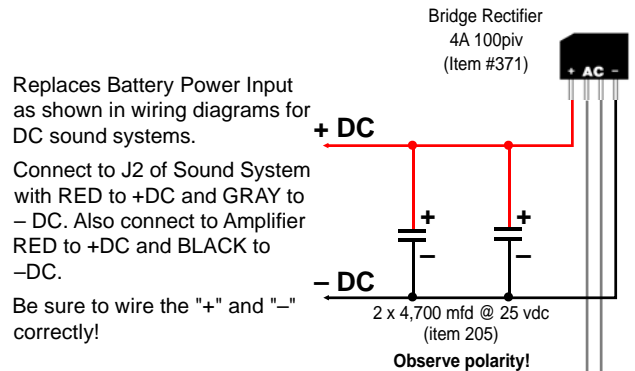

Replaces Battery Power Input as shown in wiring diagrams for DC sound systems.

Connect to J2 of Sound System with RED to +DC and GRAY to -DC. Also connect to Amplifier RED to +DC and BLACK to -DC.

Be sure to wire the "+" and "-" correctly!

* denotes connection, join wires together & insulate. Otherwise wires are just passing over and do not connect.



Capacitors shown are not necessary when using filtered DC track power. If unfiltered DC, only one may be necessary. Static in the amplifier will be the clue for more capacitance. It never hurts to have the capacitors in place for more filtering of the DC track power in the locomotive.