

AUTOMATIC BACK AND FORTH for AC powered trains - requires 3 position E-UNIT

AUTOMATIC BACK AND FORTH provides a simple means of testing locomotives on a workbench or having action on the layout that does not require an operator. This can be useful in the operation of a trolley line that would otherwise be merely scenery. This action enhances the overall motion that would normally occur during operation and adds to the illusion of activity.

This automation can be accomplished simply, using DALLEE ELECTRONICS components, in any gauge or scale. This package provides for a timed stop at each end. We also package components for DC automatic BACK-N-FORTH.

The overall AC operation is as follows:

View page 2 for the basic setup. Starting with the TRAK-DTT on the right (sequence controller), when current flow is sensed by a locomotive or trolley reaching the end rail section, will activate its relay for an adjustable time frame and then do nothing further. The relay contacts are wired to remove power from the track, sequencing the "E-UNIT". The relay must also simultaneously illuminate a ballast lamp whose power is also routed through the detection coil of the other TRAK-DTT (NEUTRAL timer). In this way current flow is used to trip the other TRAK-DTT during the stop. The neutral TRAK-DTT is wired to remove track current from flowing thru the sense coil of the first TRAK-DTT (sequence controller) routing it directly to the ends. This allows for the sequence TRAK-DTT to reset and get ready for the next trip. When the time frame has elapsed of the neutral TRAK-DTT, the relay relaxes, turning off the power to the ballast lamp and restoring track power thru the sequence TRAK-DTT sense coil. In doing so the sequence TRAK-DTT trips again sequencing the "E-UNIT". Since electronic "E-UNIT's" require next to no track current it is necessary to have something drawing power within the trolley or locomotive. This is why we suggest adding a lamp if you do not already have one on when in neutral. If you do not want to see the light from a lamp then we suggest to paint it black.

Intermediate stops would require adding another TRAK-DTT with a ballast lamp and a resistor in series with the track power to hold the "E-UNIT" in neutral. This is shown on page 3. Since current draw of each engine is so drastically different it is difficult to tell you what works exactly with each unit. In the early years it was appropriate to place a 5 to 10 ohm 10 watt resistor in series with the track. In this case you would connect the resistor across the "C" and "N/C" contacts, the same two that the outside rail wire would be connected to, so that when the TRAK-DTT trips the power to the track becomes placed in series with the resistor. It may be necessary to place more in series for the newer equipment to prevent it from creeping. Only experimentation will tell what is necessary for your exact needs.

If more than one stop of equal time is required then you need to only add more sense sections for the additional TRAK-DTT and ballast lamp. If different stop times are required then each different time requires an additional TRAK-DTT and ballast lamp.

Tips for good operation:

Because we are depending on current flow it is important that both the rail and the wheels be kept reasonably clean so that the possibility of faulty sensing is minimized. The ballast lamps also aid in eliminating faulty rail sensing by switching sense current to current flow thru the lamp. It is also necessary that the track length between the ends be long enough that there will be at least several seconds running time to allow the circuitry to reset itself so that further detection can be made.

There have been very few problems with this automation. The main problem is a lack of adequate power from some power packs, you need at least 10VA of power. If you have inadequate power intermittent operation will be experienced. A suggestion to cure this problem is to either run the 12VPS (electronics) on one power pack and run the trolley on another. When other problems have occurred it has been almost universally due to poor electrical contact causing loss of motion or a double activation and therefore, no reverse. As a precaution, with respect to a possible double activation situation, we have suggested that totally non powered sections of track be included at each end beyond the sensing rails. Should a double activation occur the locomotive or trolley would run into the non powered section and stop. You also need a non failing E-UNIT with proper track pickups.

Automatic BACK-N-FORTH using AC track power with "E-UNIT" sequencer (3 position F/N/R/N)

DALLEE ELECTRONICS, Inc.
 246 W. Main St.
 Leola, PA 17540
 (717) 661-7041
 www.dallee.com

TRAK-DTT (below) sets the time in neutral.

Set TRAK-DTT time to desired for stop at end. This must be longer than sequence time setting!

TRAK-DTT (below) sets sequence time for the E-UNIT.

Set TRAK-DTT time for next to minimum. The time must be long enough for the other TRAK-DTT to trip for neutral time!

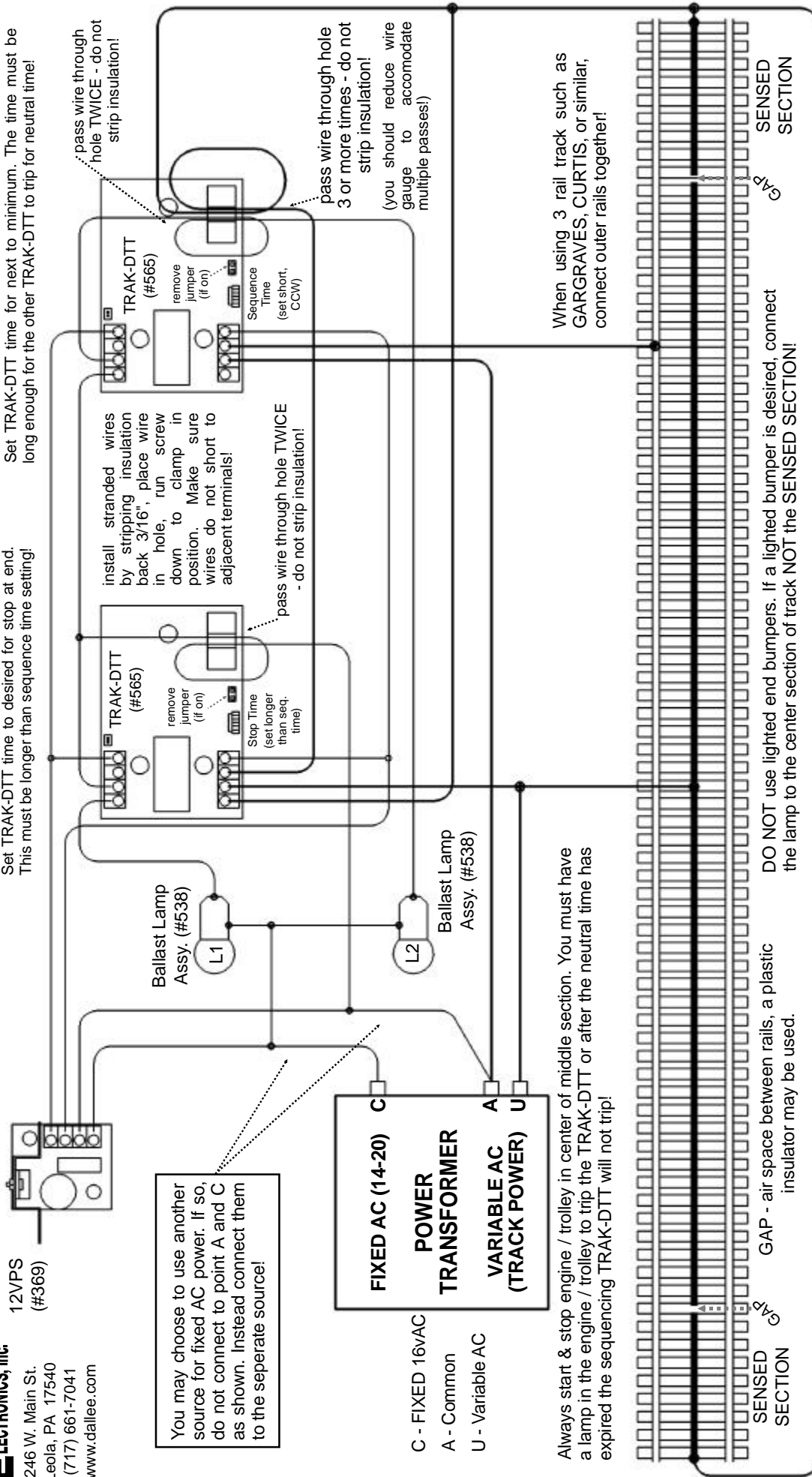

C - FIXED 16VAC
 A - Common
 U - Variable AC

Always start & stop engine / trolley in center of middle section. You must have a lamp in the engine / trolley to trip the TRAK-DTT or after the neutral time has expired the sequencing TRAK-DTT will not trip!

Automatic BACK-N-FORTH with TIMED STOP in middle using AC track power with "E-UNIT" sequencer (3 position FN/R/N)

DALLEE
ELECTRONICS, Inc.
246 W. Main St.
Leola, PA 17540
(717) 661-7041
www.dallee.com

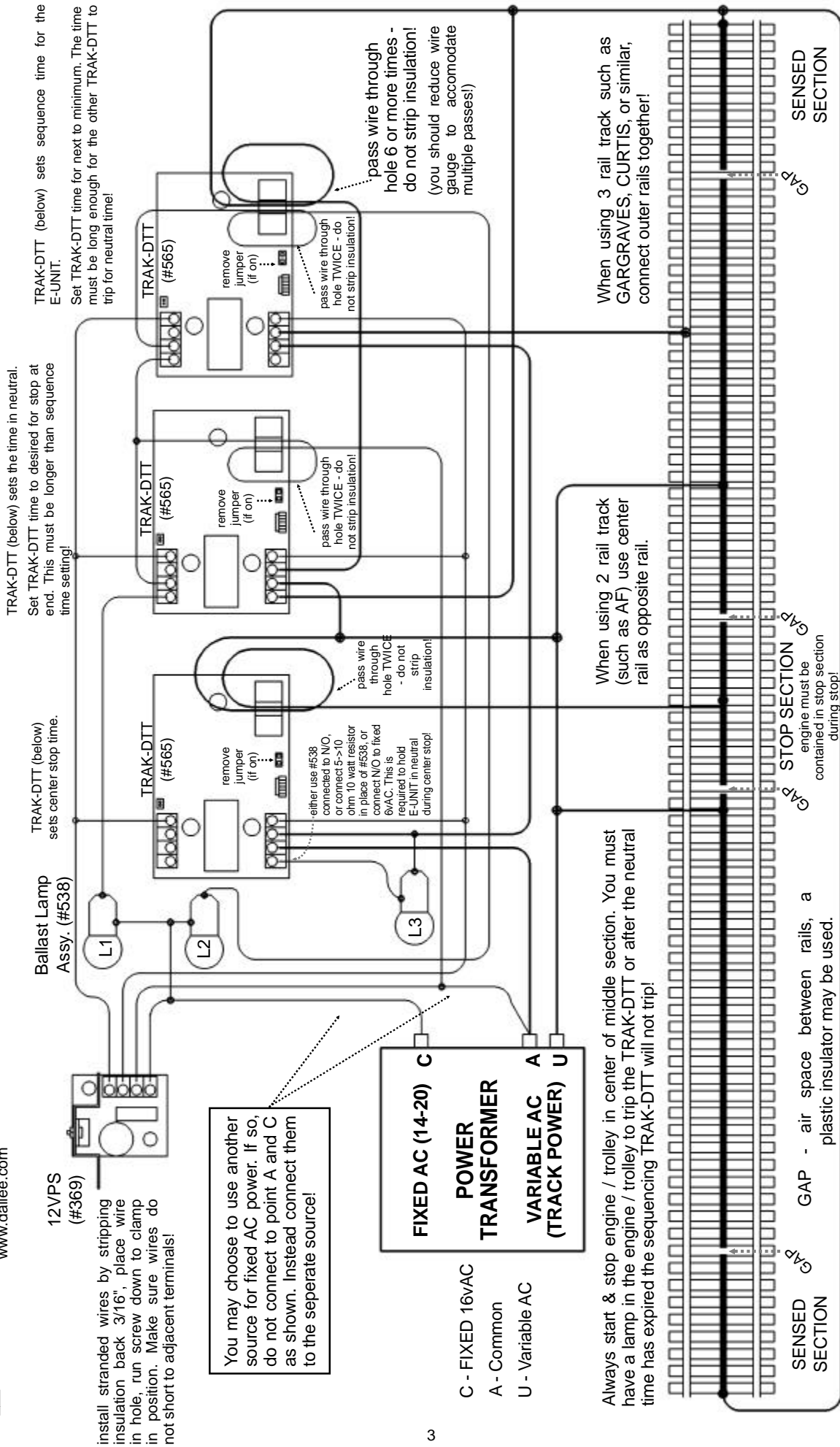

Recommended minimum distance between rail gap's is 10 feet. There is no maximum limitation. If running with cars, the last one needs to be illuminated to be sensed. The end sections from "GAP" to the end need to be at least 2 feet. It is also recommended to use end stops (not illuminated bumpers) in case the E-UNIT does not sequence properly. You may also wish to use "DEAD" track for over-runs instead of bumpers. If you want lit bumpers you can do so as long as you do not connect the center rail to the "SENSED SECTION" power feed (located at each end section) instead, connect it to the center section power feed leaving a gap in the center rail to each shown end "SENSED SECTION". More stops can be added to this setup. If the E-Unit changes direction (resets to the forward position) during a center stop, more voltage on the track is needed during the stop. A simple solution, in lieu of fixed AC as shown, is to place another ballast lamp in parallel with L3.