

DIESEL SOUND with Automated Horn play patterns by

DALLEE
ELECTRONICS, Inc.

DCv3 AH rv8

CAUTION: this device can be damaged by static discharge. Please exercise care during installation to avoid this possibility. Discharge yourself to an electrical ground (outlet cover screw) before removing this device from its anti-static bag. Please read instruction sheet completely before attempting to install and operate this product. Save the anti-static bag for possible reuse of storing or shipping the sound unit!

OVERVIEW: This device is an electronic, self contained, sound system for installation in model diesel locomotives that are designed to operate with conventional DC track power or other types of control systems including radio with either track or battery power, also as a stationary sound unit. Because of its dimensions (2.7" x 0.9" x approx. 0.5" high) the sound system may be limited to installations in some powered units making the need for use of a "dummy" unit or a trailing car. This unit differs from the standard DC type sound systems in that it contains automatic Horn play patterns each time the input is triggered. Triggering the play patterns is done by the use of a reed switch passing a fixed magnet. The Bell is also triggered on and off in the same manner. Large gauge "G" operators usually place the reed switch beneath the locomotive. One side is used for the Horn, the other side for the Bell. Magnet trips are then placed in the track. Another method of operation is to operate the sound system as a stationary unit and place the magnets on the underside of an engine or car.

An on/off switch (not included) must be used to power the sound unit on and off in some applications. The audio amplifier can produce 1.1 watt of power which is in excess of what most small speakers can handle. If more audio power is desired, an amplifier such as item #671 or #672 can be used. The speaker impedance must be 8 ohms or higher. Sound volume is adjustable. Refer to our catalog for available speakers. Always try to use the largest size speaker for the space allotted or multiple cluster's of four smaller speakers also works well.

Sounds produced via momentary reed switch closure are automated horn patterns, and a bell. Non-user controllable sounds include periodic air system pressure release, brake release and diesel prime mover sound automatically adjusted to speed and load conditions.

INSTALLATION INSTRUCTIONS:The sound system consists of a printed circuit board, a speaker, four 2-pin connectors with wires and one 3-pin connectors with wires. Refer to the drawing on page 2 to familiarize yourself with the connectors and controls on the sound board. Then refer to the specific instruction sheets for the type of installation you intend to make. Before proceeding with the installation read the balance of the instructions carefully so you will be completely familiar with what is required and what sounds you should hear.

The circuit board should be mounted so that at minimum, the volume control is accessible either through the frame or via a hatch or a hole in the locomotive body shell. Be certain that the components on the circuit board do not come in contact with any metal objects as such contact can destroy the sound system. The speaker should be mounted as per available space bearing in mind that sound reproduction is enhanced when a speaker is properly enclosed and baffled.

If a DC locomotive is not moving, there is no track power, therefore to have sound it is necessary to have a separate power supply for the sound system. For in locomotive use, this separate supply is a battery. Without a battery, the sound will not work at lower track voltages. For some this is not a problem. Drawings are supplied for multiple types of connections. If using batteries, we suggest the use of one 9 volt or 6 AA or 6 AAA batteries in series to maximize volume potential and battery life. Rechargeable batteries can be used. When connecting the battery (DC) power leads be absolutely certain that wires connect to the proper DC input leads.

Installation of the reed switches is easily done by making the appropriate wire connections and placing the reed switch in the proper location for magnet activation. When removing the reed switches, be careful not to crack the glass. Do not bend the leads at the glass ends, use a needle nose pliers to hold the wire entering the glass and then bend the wire. Bending at the glass will

break or deform the alignment of the reed switch. Carefully solder wires and cut excess lead ends. Reed switches are not warranted under any circumstance since they are quite fragile and easily broken physically and electrically. Extra reed switches are available, item 989. After appropriate lengths of wire are placed on the reed switch, secure the reed switch with either double sided tape (item 388) or other type of glue. Make sure that all wires to the reed switches and sound system do not come into contact with any other metal or power wire since this may damage the sound system.

If any connections are not done properly, especially the power connections, you will damage the sound system. This type of damage is not covered under any warranty. The sound system is thoroughly tested and inspected before packing to insure proper function. There is a minimum charge of \$40.00 plus s/h for repair.

SPEAKER MOUNTING: The speaker generally should be mounted so that the sound can actually "get out" of the locomotive. A hole in the floor or fuel tank is acceptable but open grills or a doorway may be a better choice as the sound can exit upward rather than down toward the track. In some cases, particularly with plastic body shells, just mounting the speaker against the shell will be adequate as the vibrations of the shell can enhance the sound. Enclosing the speaker in a chamber will also enhance sound reproduction. A very simple enclosure can be made with a tube. The longer the tube the better the speaker will reproduce low frequency sound which is inherent in diesel prime movers. It is usually best to seal the end of the tube, so there are no air passages to the rear of the speaker, thus creating a sound chamber. By carefully sealing all openings it may be possible to use the entire body shell as a sound chamber. A simple wall behind the speaker may be all that is possible or perhaps all that is needed.

Speakers can be attached with double sided tape, with glue or with "hot melt". Enclosures can be made with plastic, wood, card stock or even metal. Film cans or medicine bottles make excellent sound chamber enclosures for small diameter speakers. Attachment with "hot melt" is advantageous as the "hot melt" can be used as a gap filler when creating an enclosure.

A second speaker, wired in series with the main speaker, can also enhance sound quality and will permit a higher volume without damage to the individual speakers. A tube with a speaker at each end or a speaker in a doorway at each end of a body shell is an excellent approach. A four speaker approach will yield the highest volume while still maintaining the 8 ohm minimum requirement. Drawings for this are included in the speaker instructions.

Speaker enclosure is an art and experimentation is definitely in order for your installation so as to gain the maximum benefit of the superb sound quality available in this sound system.

SOUND INFORMATION:

All sounds are discussed assuming that the sound unit is fully powered at all times. If only powered from track power, the sounds will only start when sufficient track voltage is obtained.

PRIME MOVER (DIESEL): sounds range from idle to full RPM with eight notches. With no power to the track / motor the sound system will produce engine idle sounds. As a throttle is advanced to put the locomotive in motion, a brake release will sound (see below) and the diesel will initially accelerate to notch #4, and then seek the correct notch setting for locomotive speed. There will be a distinct volume increase during acceleration.

AIR RELEASE (POPS): Air is pumped continuously in a diesel locomotive to maintain pressure in the brake system and for other purposes. Periodically the pressure will increase and the excess will be released through the safety valve. These AIR RELEASE sound (pops) are generated at random intervals during idle and at all notch settings.

BRAKE RELEASE: sound is produced when the throttle is advanced from the idle position. This brake release should always precede locomotive movement but will only occur if the diesel sound is actually at idle. For DC operators, this requires approximately 1.5 to 2 volts of input voltage to sense a running mode.

HORN: sound is controlled by the reed switch trigger. Upon closure of the reed switch via an external magnet, the sound system will begin to play appropriate Horn patterns. Each activation will trigger a different Horn signal (play pattern). We used appropriate railroad patterns for a moving train.

BELL: sound is first activated by passing the reed switch trigger. After the bell has rung a few times, it may be triggered off by passing the reed switch over the magnet again. The bell will turn off at the end of a ring.

GENERAL OPERATING INFORMATION:

VOLUME ADJUSTMENT: should be set as desired for your application. Please remember that the amplifier can produce more power than a small speaker can handle and that the sound will be louder if the speaker is properly enclosed and baffled. If you are using batteries, the louder the volume the shorter the battery life.

NOTCH ADJUSTMENT: full clockwise will yield notch #8 on the diesel at approximately 8 volts to the track / motor. Rotate the control CCW to increase the voltage required to reach notch #8. Gauge 1 and other operators using higher motor voltages will probably want to set this control full CCW. Placing a 1k resistor in series with one of the motor leads will also lower the engine RPM sound further when higher motor voltages are present.

Common Horn signals used with this sound system

<u>SOUND</u>	<u>INDICATION</u>
long, 3-short.....	flagman protect rear of train
2-short.....	acknowledgment
4-short.....	call for signals
short, long.....	inspect train line for leak or brakes sticking
2-long, short.....	approaching meet or wait point
2-long, short, long.....	approaching grade crossings
continuous long.....	approaching stations or junctions
successive shorts.....	alarm for something on track

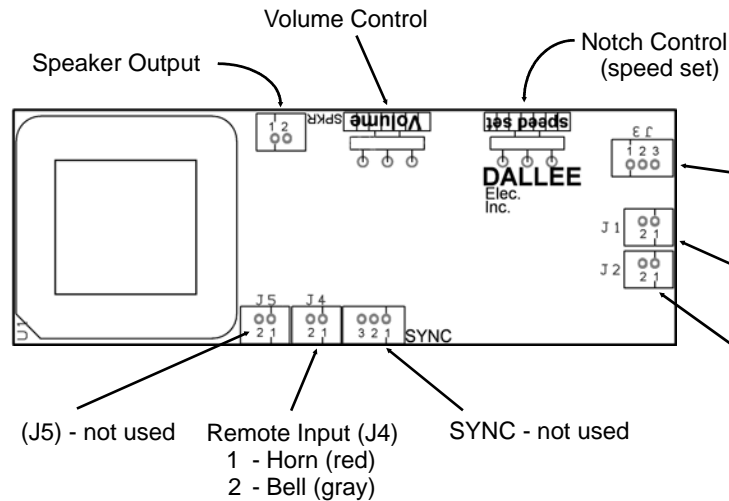

Wiring standards:
wires with a "*" ARE a connection!
wires crossing over (without a "*") DO NOT CONNECT!

SPECIFIC INSTRUCTION SHEETS

<u>PAGE</u>	<u>INSTALLATION TYPE</u>
3.....	Conventional DC
4.....	Conventional DC with rechargeable battery
5.....	Reed Sw/Magnet mounting
6.....	sample installation
7.....	sample speaker installation

Other wiring / application notes can be found on our web site under "Current Product Instruction Index" then "Sound Related, misc".

NOTE: The speaker impedance should be kept near or above 8 ohms, therefore four 8 ohm speakers in a series/parallel configuration is acceptable since it yields 8 ohms total impedance. If you care to use two 8 ohm speakers you **must** place them in **SERIES**.

DO NOT touch the speaker wires to anything else, this will damage the amplifier which is not covered under warranty!

When connecting DC power to the sound unit be absolutely sure that the "+" and "-" are connect correctly! If not, you will either burn out the sound unit or the supply feeding it. This is not covered under warranty!

DALLEE
ELECTRONICS, Inc.
246 W. Main St.
Leola, PA 17540
(717) 661-7041
www.dallee.com

Track power installation without batteries

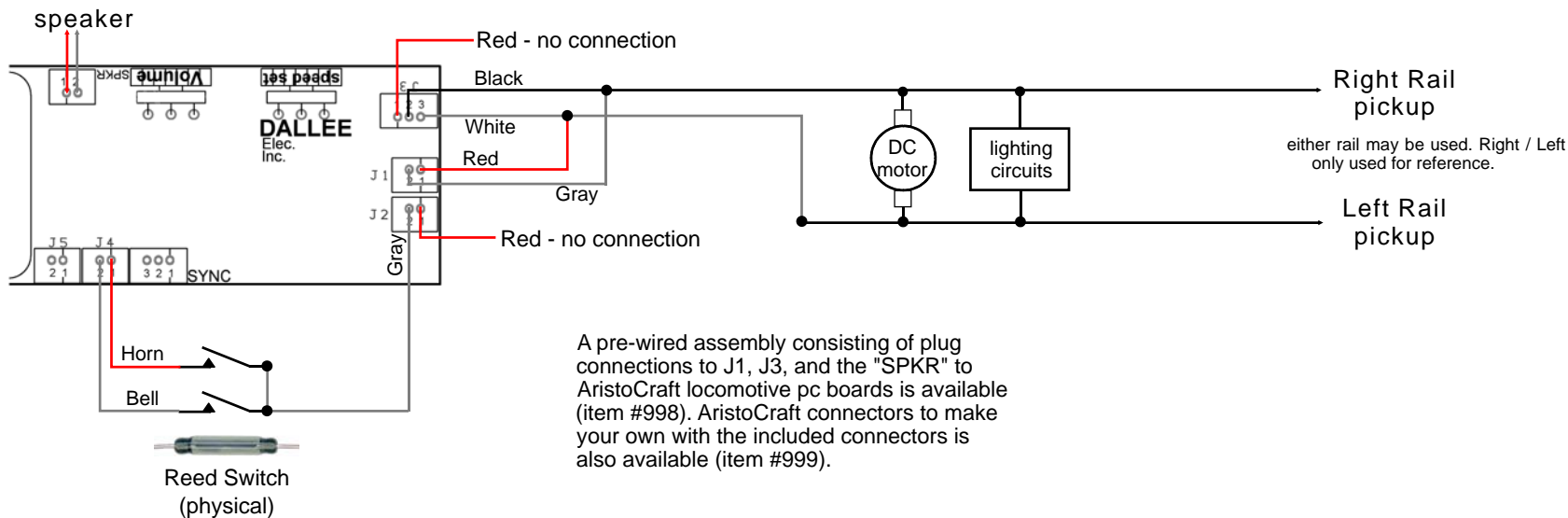

DC track power installation using standard batteries

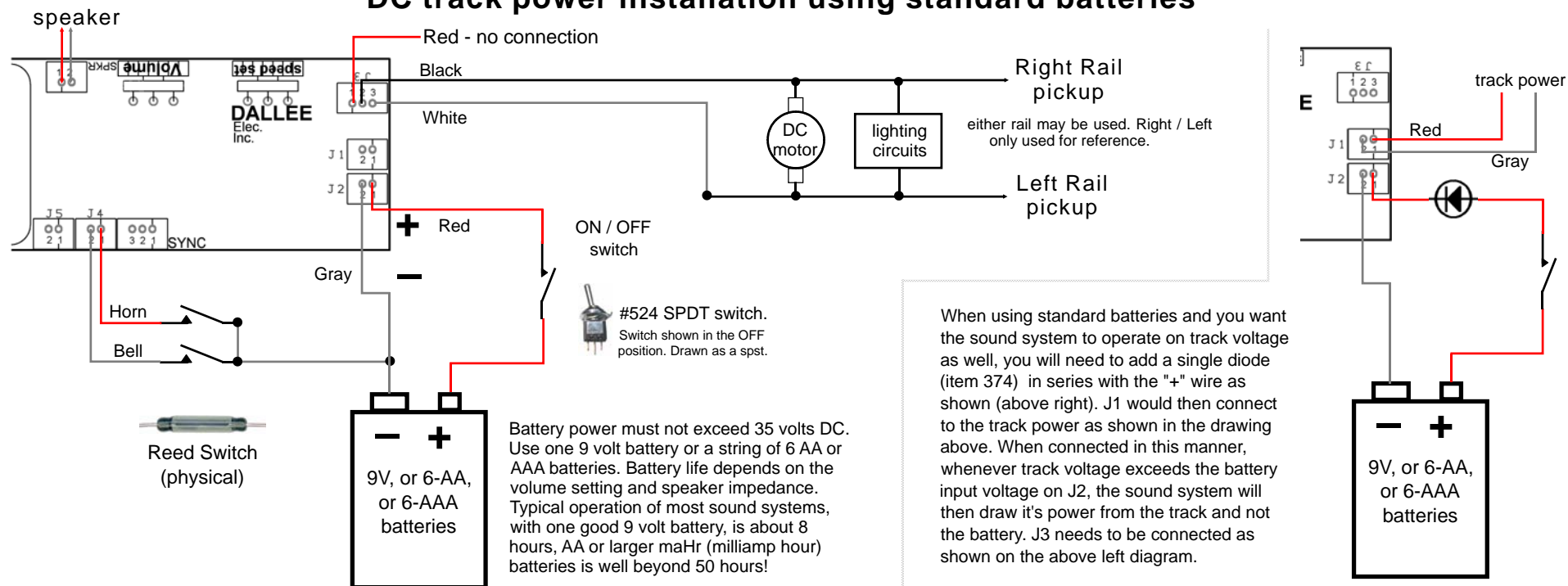

DC track power installation with rechargeable battery.

When track voltage exceeds battery voltage, the sound system will operate from track voltage instead of battery voltage.

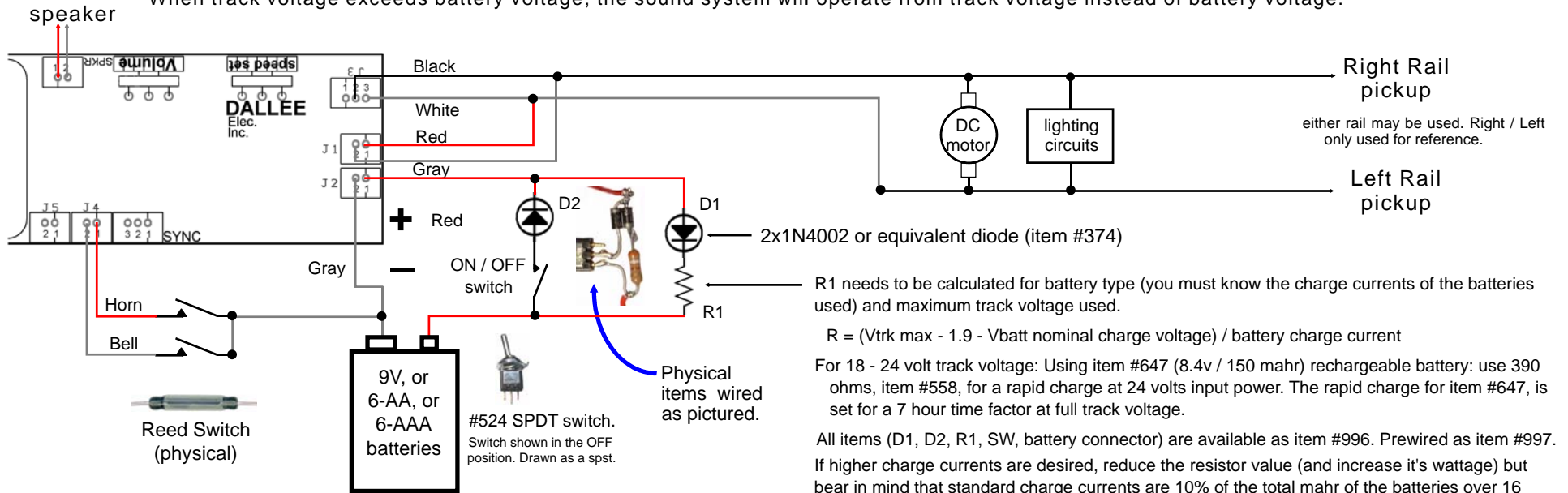

Battery power must not exceed 35 volts DC. Use one 9 volt battery or a string of 6 AA or AAA batteries. Battery life depends on the volume setting and speaker impedance. Typical operation of most sound systems, with one good 9 volt battery, is about 8 hours, AA or larger mAh (milliamp hour) batteries is well beyond 50 hours!

above with rechargeable battery & external charger connection.

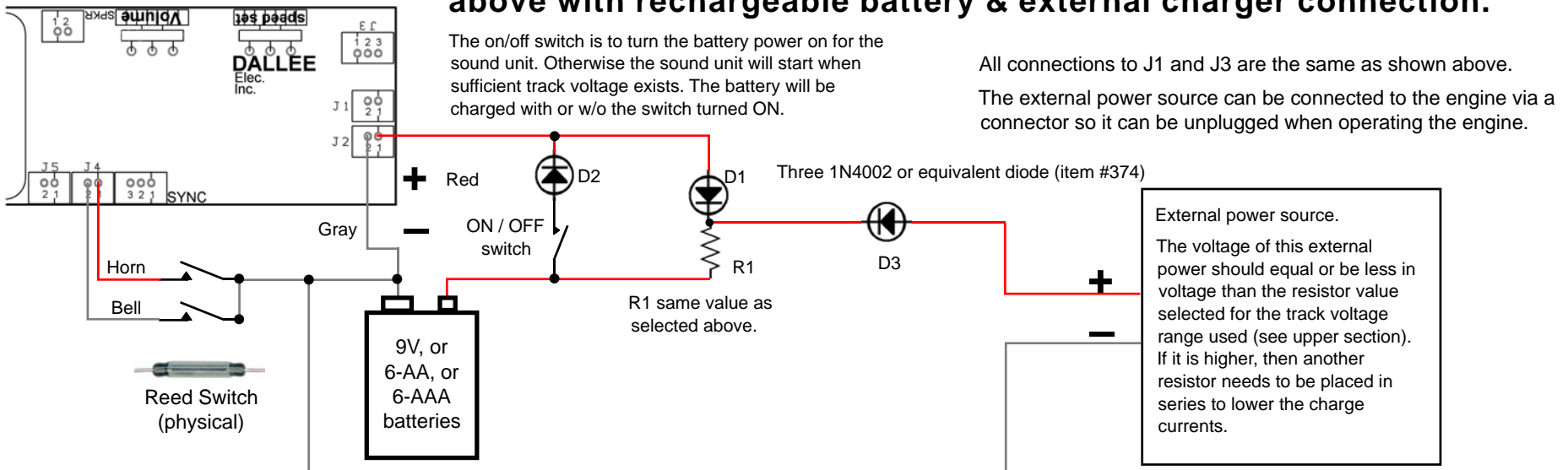

Reed switches mounted under engine or car

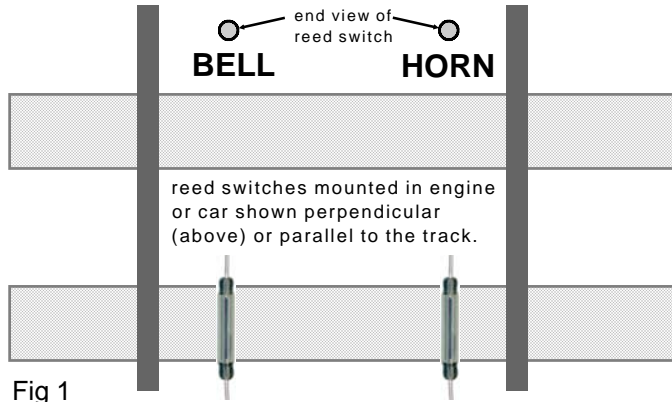

Fig 1

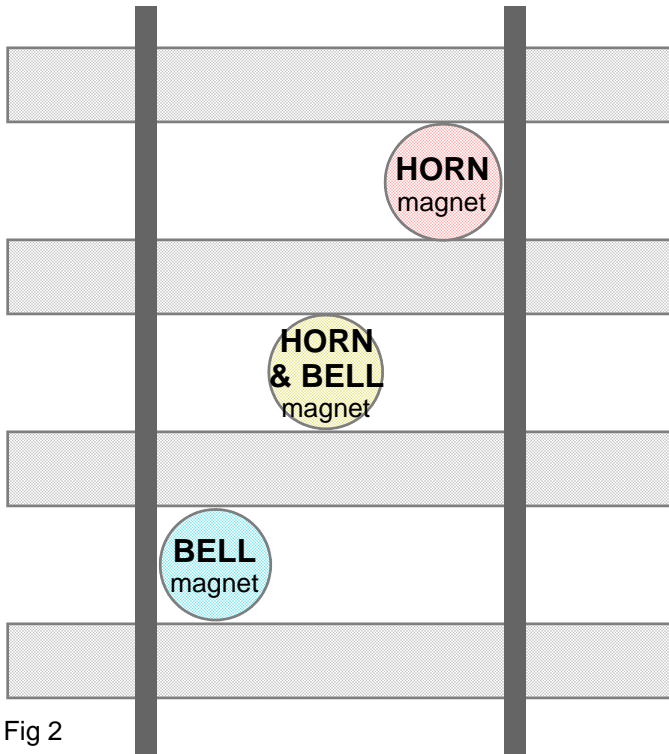

Fig 2

When operating with reed switches and magnets, it is necessary to orient the reed switch for the best sensitivity. If you need to experiment with your magnet's polarization properties, connect the reed switch to a small lamp and move the magnet about to turn the lamp on/off. This will give you a very good idea as to which way the reed switch needs to be oriented vs the magnets polarization. Reed switches can be easily mounted with double sided foam tape (item 388).

Mounting methods:

1 - Perpendicular to plane of track: The easiest to mount in most cases would be to mount the reed switch perpendicular to the track plane. By doing so, you minimize the sensitive area of the reed switch and make it more selective for what the magnet is going to operate. As can be seen in the top section of fig1 on this page. The magnets are strategically located to trigger each function. By proper locating the magnets, individual functions can be controlled (fig2).

2 - Parallel to plane of engine:

Method 1: Mount the reed switches 90° from that shown in the lower portion of fig1. Position the magnets over the end area of the reed switches as shown in fig 2. This way other rectangular magnets can be used as well. If you do not want this system to be triggered by certain rectangular magnets but do want it to activate with item 988 magnets, then orient the reed switch as shown in fig 1 and place the magnets directly under the reed switch. This way you could make the engine more specific as to which magnets will trigger the sound system. Fig 3 shows activation with a rectangular magnet.

Method 2: For use with item 988 magnets you can orient the reed switch "in line" with the locomotive. This will not yield selective operation but will allow them to operate with other magnets.

Don't forget, you do need two triggers for the bell. One to trigger the bell "on" and another further down the track, to trigger the bell "off". As shown in fig 2, you could trigger the Horn and Bell with one magnet, item 988, properly placed.

The distance between the magnet and trigger needs to be 1" or less for reliable operation. When traveling at fast speeds, and you do not get a trigger, either decrease the magnet distance or place another magnet in the line of travel.

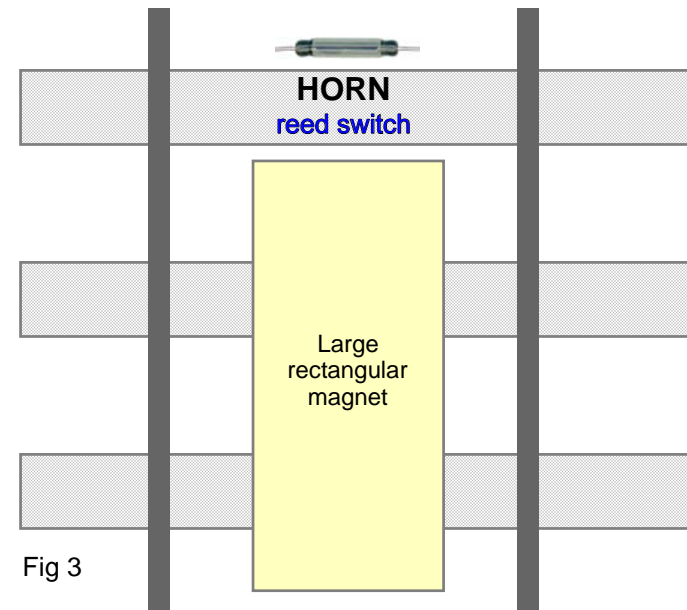
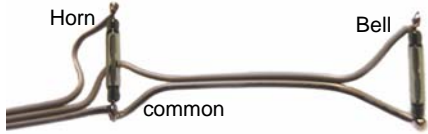

Fig 3

Since magnet strength and reed switch sensitivity varies, you may need to adjust placement to suit your needs. The basic scheme is shown for proper magnet placement. Do not place magnets exactly opposite of each other.

Sample Installation - AristoCraft GE shown

1 - Reed Switches - locate and prewire the reed switches as shown. Since they both connect to a common wire, only 3 wires are needed between them and the sound board.



2 - Since one reed switch controls the Horn and the other controls the Bell, they need to be mounted on opposite sides of the chassis. These are shown below, attached with double sided tape (item 388), inside the fuel tanks end. To keep things consistent, use the right side of the engine for Horn activation and the left for Bell. By wiring all engines the same way, it is easy to know which side activates which function.

Note: You may want to test the activation distance for the reed switches before final assembly. Since not all reed switches are made alike, some will activate at a very low magnetic field strength and others at a higher strength. The higher strength isn't the problem as much as a lower strength. A lower strength reed switch might activate from a magnet located on the opposite side of the rail (from a far distance). This is tested by using an ohm meter to test for closure of the reed switches or by wiring to the sound system and passing a magnet for the opposite activation.



Bell Reed Switch in front of fuel tank.

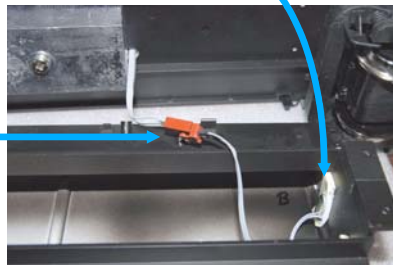

3 - for ease of disassembly, a 3 pin connector, item 521, was used between the fuel tank and bottom chassis. A hole is needed in the chassis for these wires. Make sure it is deburred properly.

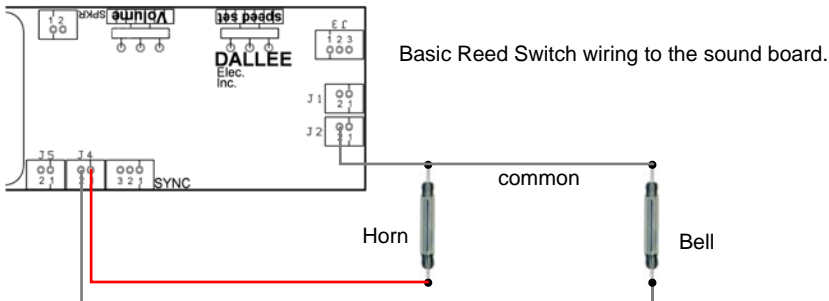

4 - A sound on/off switch (item 524) can be easily mounted by drilling a small hole in the shell as shown. Place it in the same direction as the other switches. This way the "ON" position will be easily known.

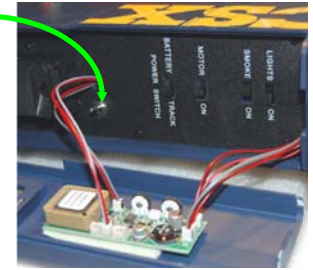

5 - as can be seen above, the sound board is easily mounted in the switch access roof panel. It not only clears all of the other switches when mounting this way, but access to the volume and notch setting controls are easily accomplished. As can be seen, all wires to the sound board pass through the existing openings.

6 - connecting J3, the motor input sense wires. In this application, we decided to utilize the motor switch that already exists instead of wiring the motor leads (white and black wires from J3) directly to the track power pickups. By wiring this way, when the motor switch is set to the "OFF" position, the sound systems prime mover will merely sit at idle when the track is powered instead of ramping up/down to the applied track power. This makes for a more realistic installation so that the engine can sit fully illuminated, or not, with the sounds running at idle. You can also leave track power on to fully charge the battery if necessary without running the locomotive. If you don't care to hear the sounds, merely turn the volume control fully CCW.

J3 pin 3, White wire connects to the other motor/track power lead which is the same as the red motor wire or Sound Power as shown. J1, pin 1, also connects to this point.

J3 pin 2, Black wire.

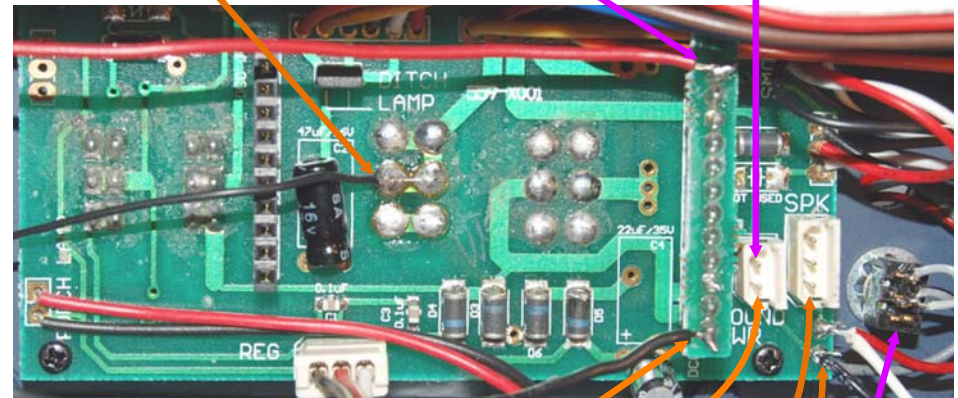

7 - Connect the other track power wire (shown as a black wire). As shown, this is the other track power wire. The sound unit's J1, pin 2 connects to this point or to the "SOUND PWR" connector.

backside of ON/Off switch, item# 524

8 - either carefully solder speaker connector wires from the sound system's connector to the main pcbd or the existing speaker. Or utilize the "SPK" connector to connect the speaker wires.

Plugs with wires for the two AristoCraft connectors are available, item #999 (ART-29608).

Sample Speaker Installations



Mounting speaker in hood of engine using a metal grill for the exhaust.

Aristocraft SD45 or other similar installations.

This locomotive and others do not have a proper speaker installation. It is necessary to make a baffle to mount the speaker with. The baffle prevents air from circulating from the front of the speaker to the rear of the speaker. Circulating air prevents the sound from proper reproduction and significantly reduces the volume!



Using the fuel tank as a speaker baffle is quite easy. In this case the speaker emanates sound into the body.



cardstock baffle - glue speaker gasket to baffle

DO NOT allow the speaker wires to contact ANYTHING else INCLUDING the chassis of the engine or the speaker frame. **This will damage the sound unit and voids the warranty.**



For open body shells it is necessary to make a speaker baffle instead of using the body for a baffle. In both cases, the backside of the speaker is closed off.

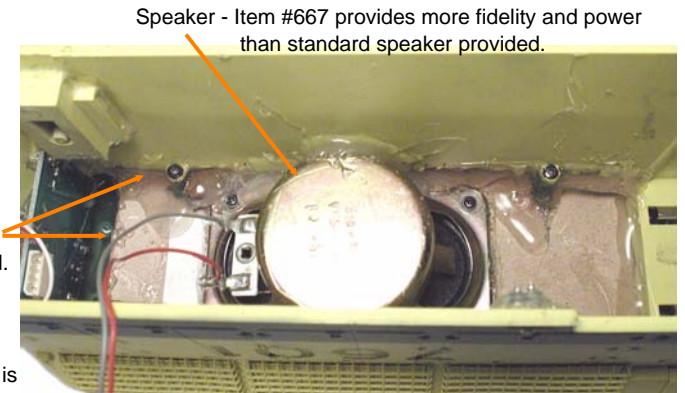

Speaker - Item #667 provides more fidelity and power than standard speaker provided.

Mount the speaker and seal all edges with either "hot melt" or silicone seal. Make sure that all edges are properly made air tight!

In this engine, the sound is projected through the fans.