

Display Operation Timing with Push Button activation for time cycle with momentum for DC operators.

When operating a display piece it is desirable for the viewer to activate the display for a fixed time. This wiring diagram and components provide that function. When the push button is activated, the Trak-DTT is activated. The Trak-DTT applies power to the track power via the MO-1 and the train will gradually start (based on the "Start" potentiometer setting) and increase to the full throttle setting. When the time, set on the Trak-DTT is reached, at which time the MO-1 will engage gradually stopping the train at a rate set by it's "Stop" setting. Multiple push buttons may be placed in parallel for multiple locations but if the operation is already started, nothing will happen and the operating time will not be extended by continually pushing the button. The push button will only perform a time function after a sequence is completed. If the train did not come to a complete stop after the Trak-DTT's time has expired and the push button is depressed, the train will again accelerate for another timed sequence. Standard timing is up to approximately 75 seconds, longer activation times (typically to 5½ minutes) can be accomplished by special order.

The wiring as shown is for DC operation in one direction.

The Ballast Lamp will only illuminate for a split second when the momentary push button switch is depressed. It will not illuminate again until after the Trak-DTT's cycle is complete and the push button is pressed again.

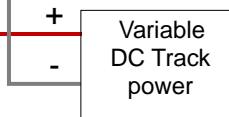
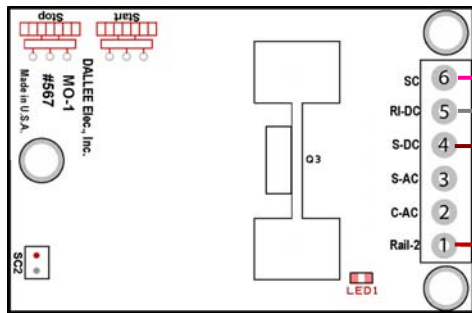
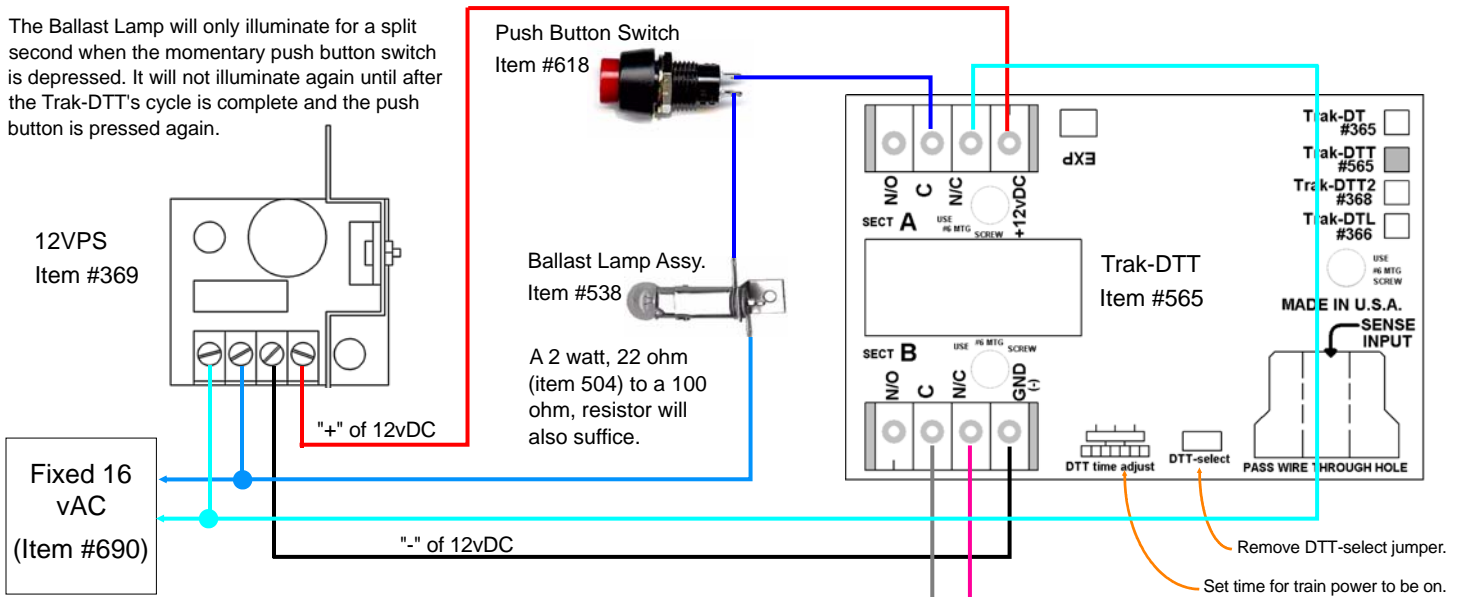

The "+" and "-" from the Variable DC Track power must be connected as shown. If you want the train to run in the opposite direction, reverse the track connections on the track side (track rail 1 and 2) and not that of the MO-1. This should be set to the maximum speed desired.

Since the MO-1 is placed in the circuit at all times, current draw must not exceed it's capabilities or unwarranted damage may occur. Therefore, make sure that the track power's transformer is properly limited for overloads such as a derailment may produce. Otherwise, place a fuse or circuit breaker in series with the track to limit the overcurrent's duration. Check the heat sink's temperature on the MO-1 (large black vertical item) to make sure it's not "toasty". If it is, too much current is being drawn by the train and it would be advisable to reduce the current to safer levels. A warm feel is OK, but a hot touch, that you can't hold onto it, is not.

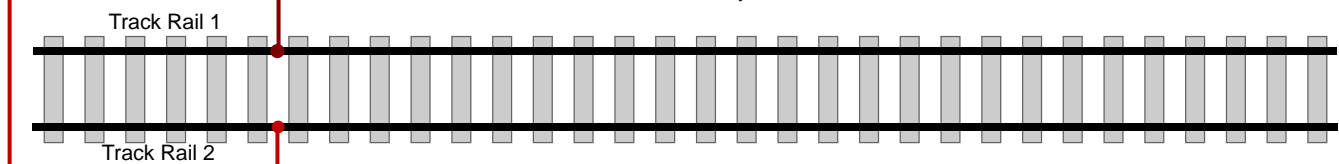

Display Operation Timing with Push Button activation for time cycle with momentum for AC operators.

When operating a display piece it is desirable for the viewer to activate the display for a fixed time. This wiring diagram and components provide that function. When the push button is activated, the Trak-DTT is activated. The Trak-DTT applies power to the track power via the MO-1 and the train will gradually start (based on the "Start" potentiometer setting) and increase to the full throttle setting. When the time, set on the Trak-DTT is reached, it which time the MO-1 will engage gradually stopping the train at a rate set by it's "Stop" setting. Multiple push buttons may be placed in parallel for multiple locations but if the operation is already started, nothing will happen and the operating time will not be extended by continually pushing the button. The push button will only perform a time function after a sequence is completed. If the train did not come to a complete stop after the Trak-DTT's time has expired and the push button is depressed, the train will again accelerate for another timed sequence. Standard timing is up to approximately 75 seconds, longer activation times (typically to 5½ minutes) can be accomplished by special order.

The variable AC Track power should be set for the maximum speed desired.

The E-Unit must be set to start in forward and is best to lock it in forward. Otherwise the E-Unit may sequence.

The Ballast Lamp will only illuminate for a split second when the momentary push button switch is depressed. It will not illuminate again until after the Trak-DTT's cycle is complete and the push button is pressed again.

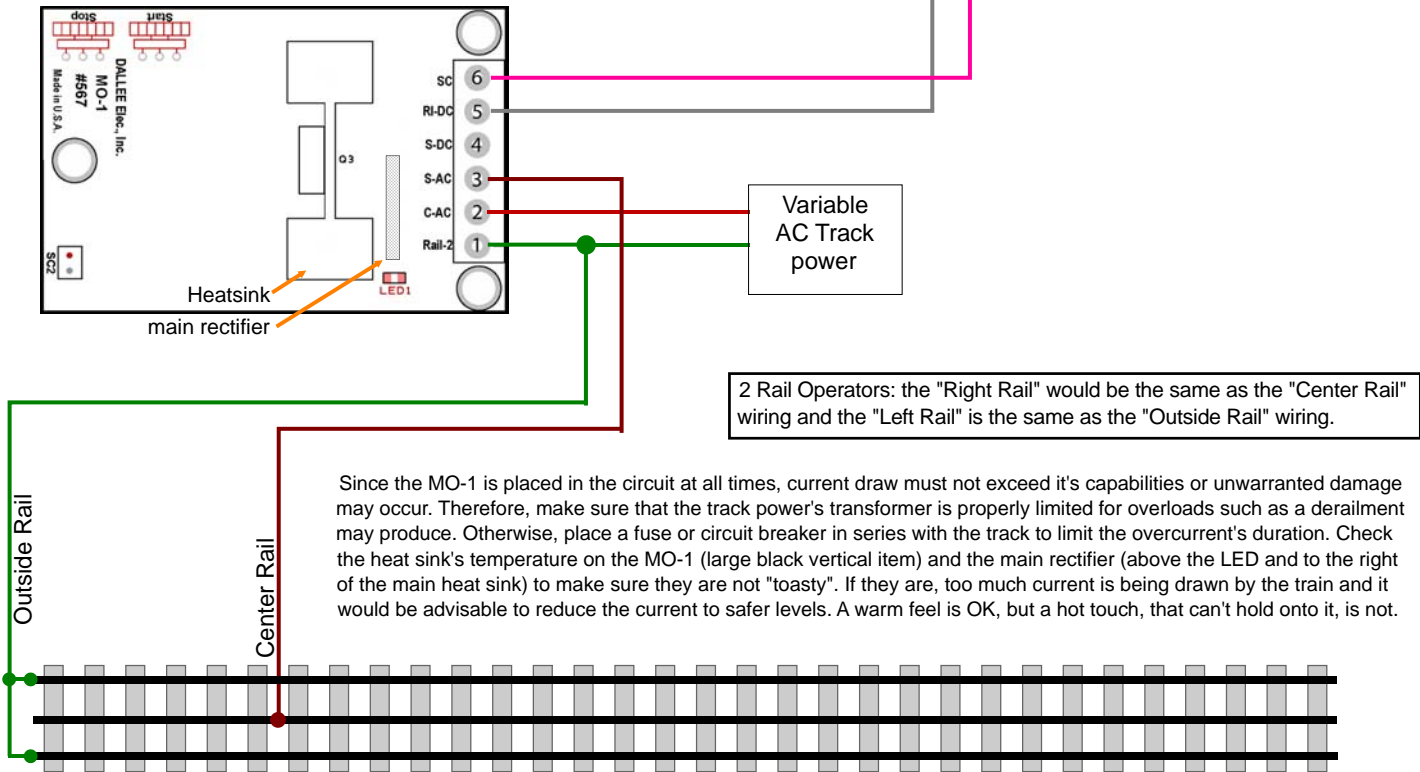
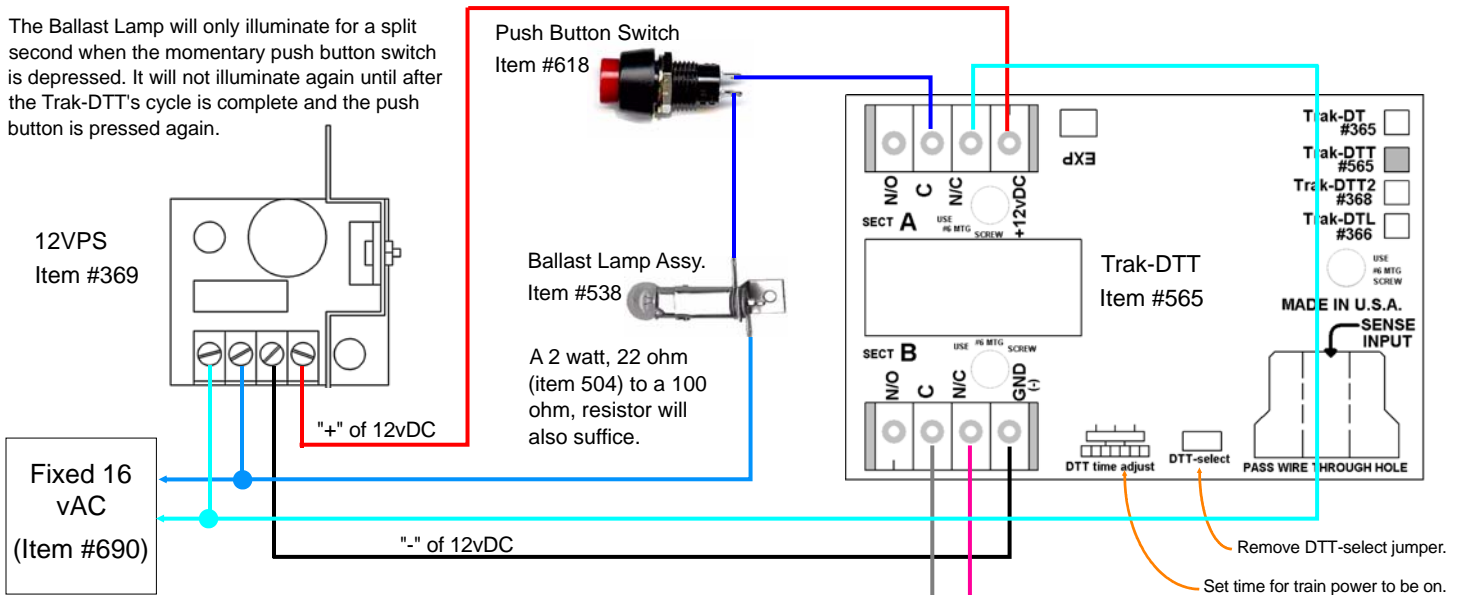

Since the MO-1 is placed in the circuit at all times, current draw must not exceed it's capabilities or unwarranted damage may occur. Therefore, make sure that the track power's transformer is properly limited for overloads such as a derailment may produce. Otherwise, place a fuse or circuit breaker in series with the track to limit the overcurrent's duration. Check the heat sink's temperature on the MO-1 (large black vertical item) and the main rectifier (above the LED and to the right of the main heat sink) to make sure they are not "toasty". If they are, too much current is being drawn by the train and it would be advisable to reduce the current to safer levels. A warm feel is OK, but a hot touch, that can't hold onto it, is not.

Display Operation Timing with Push Button activation for time cycle with momentum and fixed area stop for DC operators.

Preferred use of MO-1 since it only carries current to the train while in the stop section.

When operating a display piece it is desirable for the viewer to activate the display for a fixed time. This wiring diagram and components provide that function. When the push button is pressed, the Trak-DTT is activated. The Trak-DTT applies power to the track power through the MO-1 and the train will gradually start (based on the "Start" potentiometer setting) and increase to the full throttle setting. When the time, set on the Trak-DTT is reached, the train will continue to run until it enters the "Stop Section" at which time the MO-1 will engage gradually stopping the train at a rate set by its "Stop" setting. Multiple push buttons may be placed in parallel for multiple locations but if the operation sequence is already started, nothing will happen and the operating time will not be extended by continually pushing the button. The push button will only perform a time function after a sequence is completed. If the train does not come to a complete stop in the "Stop Section" after the Trak-DTT's time has expired and the push button is depressed, the train will again accelerate for another timed sequence. Standard timing is up to approximately 75 seconds, longer activation times (typically to 5½ minutes) can be accomplished by special order.

The wiring as shown is for DC operation in one direction.

The Ballast Lamp will only illuminate for a split second when the momentary push button switch is depressed. It will not illuminate again until after the Trak-DTT's cycle is complete and the push button is pressed again.

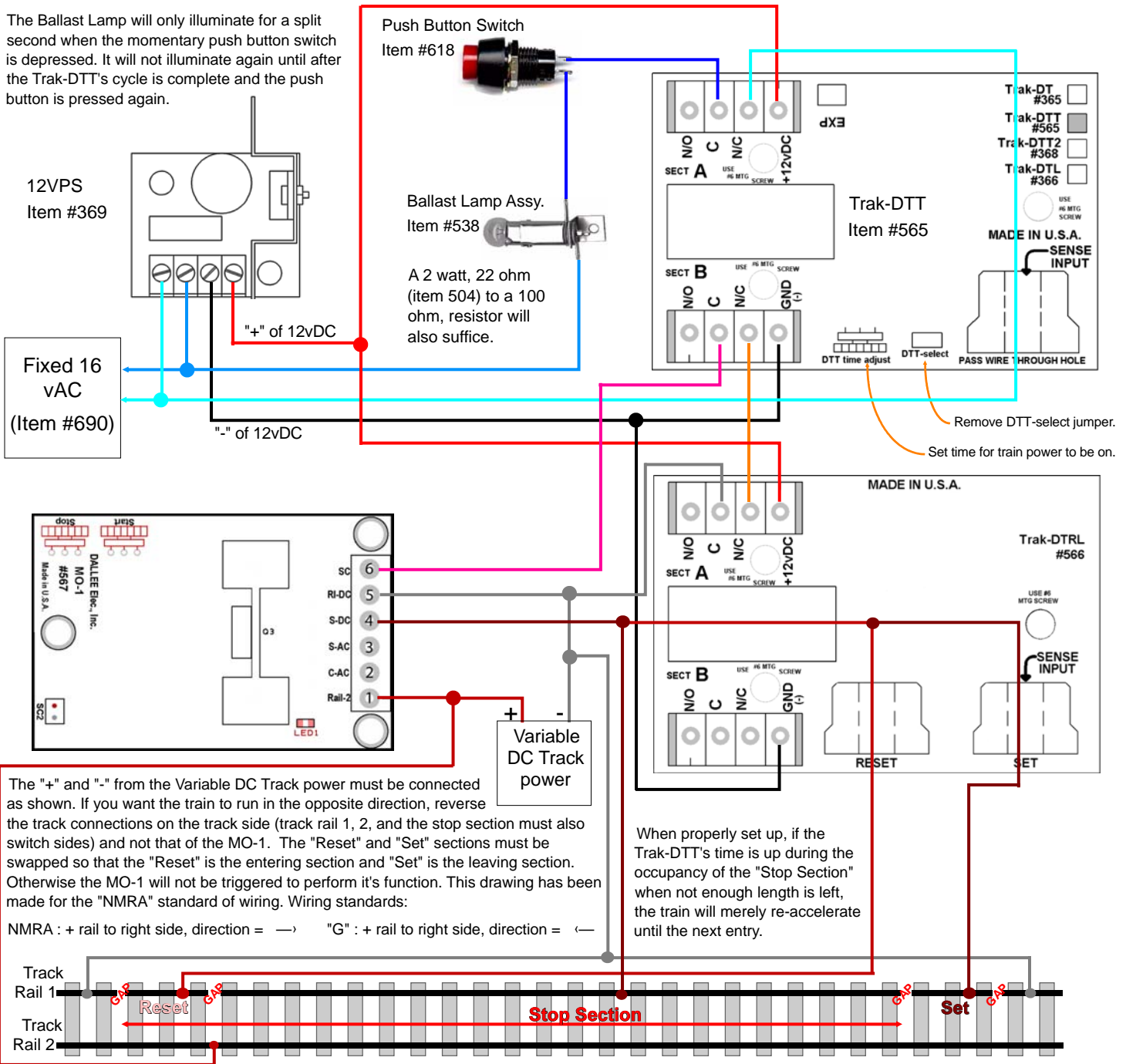

The "Stop Section", located between the gap's, must be long enough to allow the train to come to a complete stop within that section. The MO-1 will start its deceleration when the Trak-DTT's time cycle is completed and the train enters the Stop Section. If the train does not stop before the "Set" section, then it will re-accelerate without coming to a full stop.

The "Reset" and "Set" sections should be the length of one engine. The "Stop Section" length will vary as the "Stop" setting on the MO-1 is changed as well as the "Variable DC Track power" is changed. The faster the top end speed, the longer it will take to decelerate. Therefore these settings need to be set for how you are operating and the length desired.

Display Operation Timing with Push Button activation for time cycle with momentum and fixed area stop for AC operators.

Preferred use of MO-1 since it only carries current to the train while in the stop section.

When operating a display piece it is desirable for the viewer to activate the display for a fixed time. This wiring diagram and components provide that function. When the push button is pressed, the Trak-DTT is activated. The Trak-DTT applies power to the track power through the MO-1 and the train will gradually start (based on the "Start" potentiometer setting) and increase to the full throttle setting. When the time, set on the Trak-DTT is reached, the train will continue to run until it enters the "Stop Section" at which time the MO-1 will engage gradually stopping the train at a rate set by its "Stop" setting. Multiple push buttons may be placed in parallel for multiple locations but if the operation sequence is already started, nothing will happen and the operating time will not be extended by continually pushing the button. The push button will only perform a time function after a sequence is completed. If the train does not come to a complete stop in the "Stop Section" after the Trak-DTT's time has expired and the push button is depressed, the train will again accelerate for another timed sequence. Standard timing is up to approximately 75 seconds, longer activation times (typically to 5½ minutes) can be accomplished by special order.

The variable AC Track power should be set for the maximum speed desired. The E-Unit must be set to start in forward and is best to lock it in forward. Otherwise the E-Unit may sequence.

The Ballast Lamp will only illuminate for a split second when the momentary push button switch is depressed. It will not illuminate again until after the Trak-DTT's cycle is complete and the push button is pressed again.

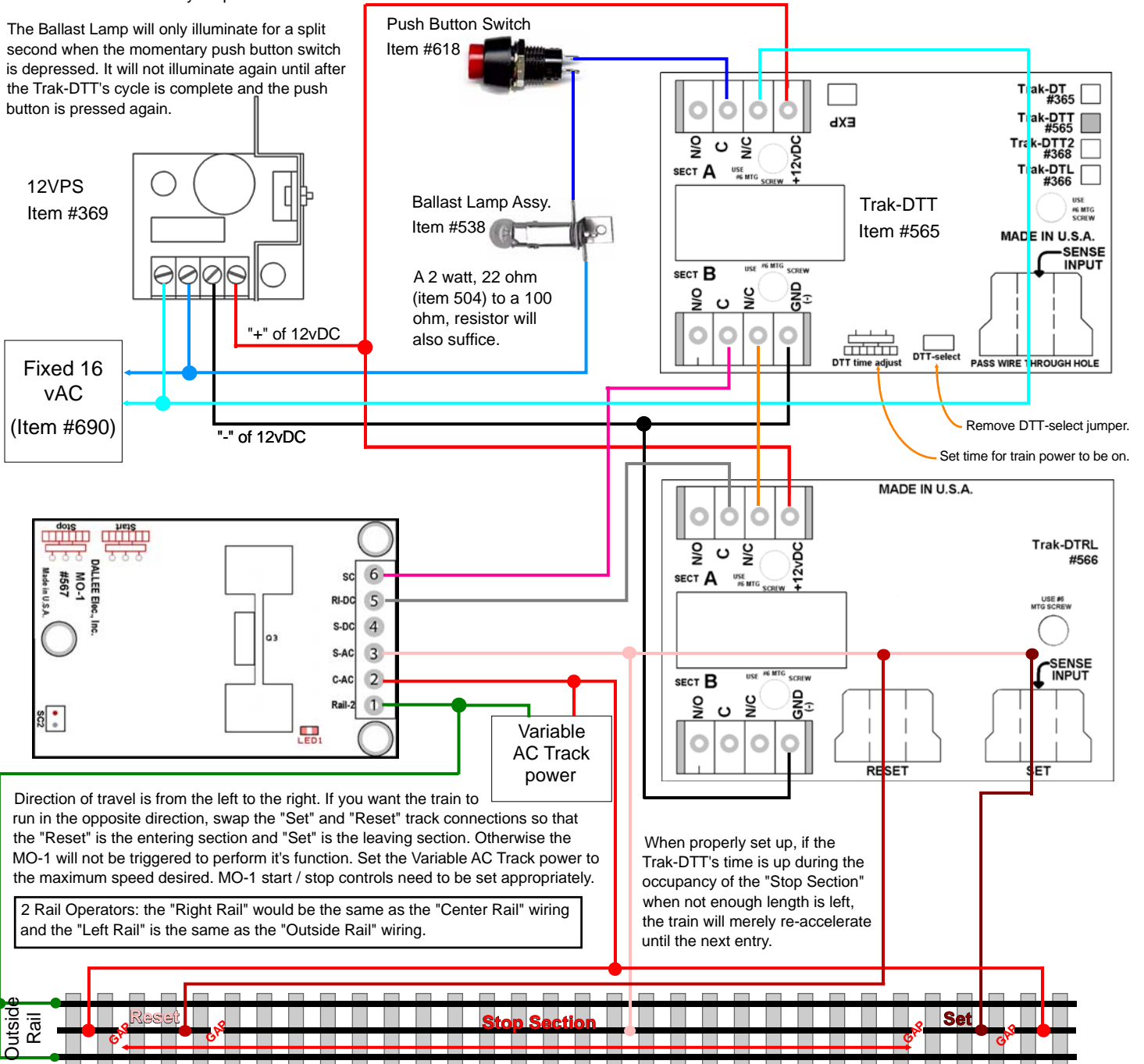

The "Stop Section", located between the gap's, must be long enough to allow the train to come to a complete stop within that section. The MO-1 will start its deceleration when the Trak-DTT's time cycle is completed and the train enters the Stop Section. If the train does not stop before the "Set" section, then it will re-accelerate without coming to a full stop.

The "Reset" and "Set" sections should be the length of one engine. The "Stop Section" length will vary as the "Stop" setting on the MO-1 is changed as well as the "Variable AC Track power" is changed. The faster the top end speed, the longer it will take to decelerate. Therefore these settings need to be set for how you are operating and the length desired.

Display Operation Timing with Push Button activation for time cycle with momentum and fixed area stop for DC operators.

Preferred use of MO-1 since it only carries current to the train while in the stop section.

When operating a display piece it is desirable for the viewer to activate the display for a fixed time. This wiring diagram and components provide that function. When the push button is activated, the Trak-DTT becomes activated. The Trak-DTT turns on the track power via the MO-1 and the train will gradually start (as per the "Start" potentiometer setting) and proceed to full speed. When the time, set on the Trak-DTT is up, the train will continue to run until it enters the "Stop Section". Then the MO-1 will engage gradually stopping the train at a rate set by its "Stop" setting. Multiple push buttons may be placed in parallel for multiple locations but if the train is running or already started, nothing else will occur. Time will also not become extended by continually pushing the button. The push button will only perform a time function after the time is completed. If the train did not come to a complete stop after the Trak-DTT's time has been exhausted and the push button is depressed, the train will again proceed to accelerate for the time duration. Standard timing is up to approximately 75 seconds, longer activation times (typically to 5½ minutes) can be accomplished by special order.

The wiring as shown is for DC operation in one direction.

The Ballast Lamp will only illuminate for a split second when the momentary push button switch is depressed. It will not illuminate again until after the Trak-DTT's cycle is complete and the push button is pressed again.

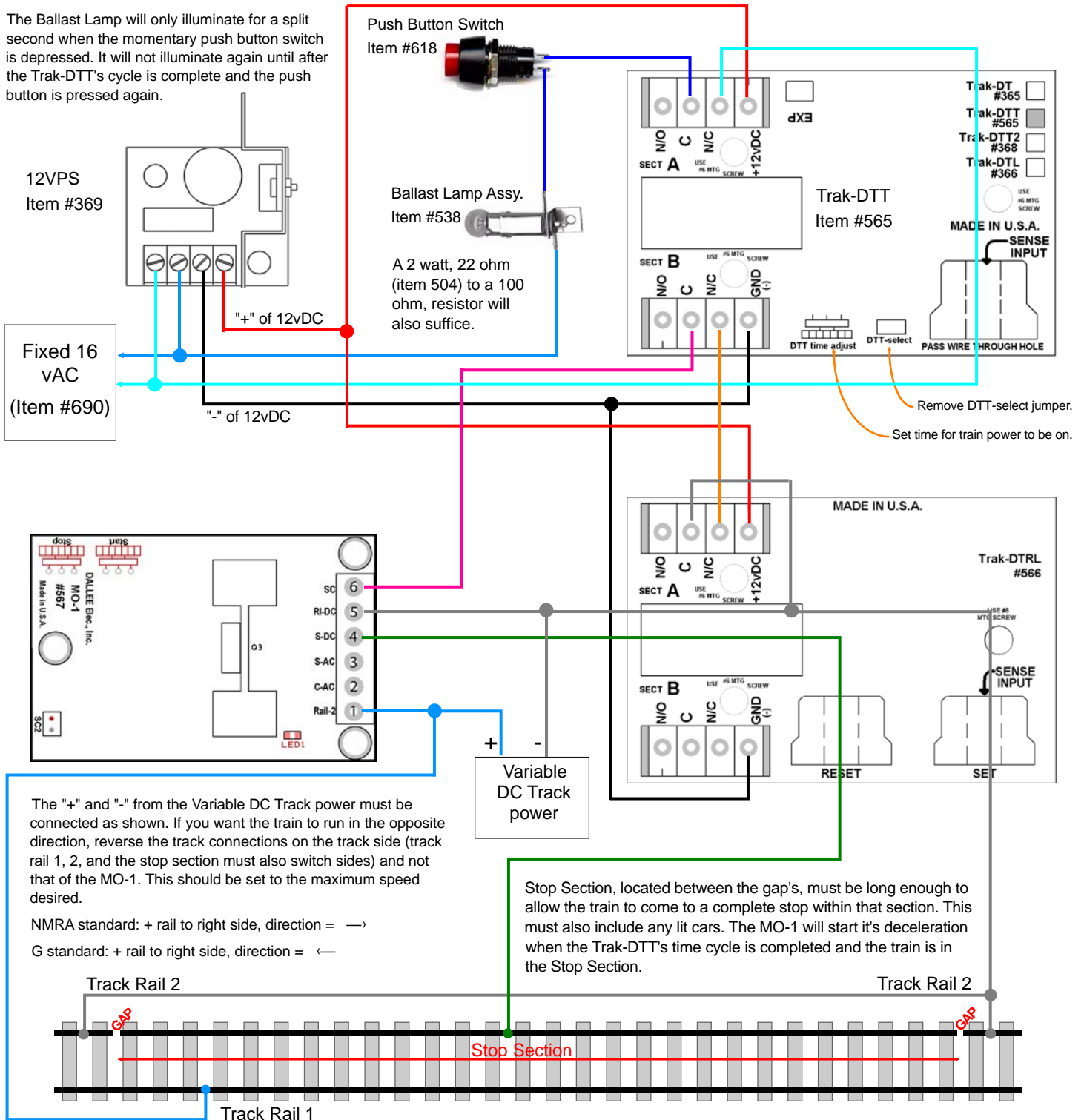

Display Operation Timing with Push Button activation for time cycle with momentum and fixed area stop for AC operators.

Preferred use of MO-1 since it only carries current to the train while in the stop section.

When operating a display piece it is desirable for the viewer to activate the display for a fixed time. This wiring diagram and components provide that function. When the push button is activated, the Trak-DTT becomes activated. The Trak-DTT turns on the track power via the MO-1 and the train will gradually start (as per the "Start" potentiometer setting) and proceed to full speed. When the time, set on the Trak-DTT is up, the train will continue to run until it enters the "Stop Section". Then the MO-1 will engage gradually stopping the train at a rate set by its "Stop" setting. Multiple push buttons may be placed in parallel for multiple locations but if the train is running or already started, nothing else will occur. Time will also not become extended by continually pushing the button. The push button will only perform a time function after the time is completed. If the train did not come to a complete stop after the Trak-DTT's time has been exhausted and the push button is depressed, the train will again proceed to accelerate for the time duration. Standard timing is up to approximately 75 seconds, longer activation times (typically to 5½ minutes) can be accomplished by special order.

The variable AC Track power should be set for the maximum speed desired.

The E-Unit must be set to start in forward and is best to lock it in forward. Otherwise the E-Unit may sequence.

The Ballast Lamp will only illuminate for a split second when the momentary push button switch is depressed. It will not illuminate again until after the Trak-DTT's cycle is complete and the push button is pressed again.

