

# E-UNIT

ITEM #518

for DC "CAN" MOTORS requiring up to  
2 ampere motor current.

## OVERVIEW:

"E" units provide sequential direction control of model locomotives that are designed to operate with AC track power. Some "E" units had only forward and reverse positions, however the vast majority function with a FORWARD - NEUTRAL - REVERSE - NEUTRAL - FORWARD sequence as track power is interrupted. Unintentional power interruptions caused by track dirt or gaps in the rails such as at switch turnouts tend to be ignored by this electronic "E" unit so the possibility of accidental sequencing is minimized. Unlike mechanical "E" units which retain their last position, this electronic "E" unit will revert to an initial "power on" state after power has been interrupted for an extended period of time. This initial state can be either FORWARD or NEUTRAL.



246 W. Main St.  
Leola, PA 17540  
(717) 661-7041  
www.dallee.com

## INSTALLATION INSTRUCTIONS:

Install the "E" unit where space permits, using the attached mounting tape, being careful that no bare wires or other metallic objects come in contact with the components or the circuit board.

Refer to figure #1 and position the board to match. At the right hand side of the board are two, two (2) pin headers which encompasses connections 1 and 2. These connections are made with two, two (2) place connectors with wires attached. Since all of the connectors use the same color pair of wires it is recommended that you mark the body and mate with markers to indicate which connector goes to which mate. Improper connections will destroy the "E" unit and are not covered under any warranty. Whenever unplugging the connectors DO NOT pull on the wires! Only unplug the connectors by placing your nail or other thin item on the edges of the connector and pull upwards from the board. Pulling on the wires will damage the connections of the wire inside the connector.

Connection 1 is the track power input labeled "TRK". The red and gray wires need to be connected to the input power coming from the track. The gray wire is to be connected to the center rail pick up rollers, right hand rail for two rail installations. The red wire is to be connected to the locomotive frame ground and thus to the outside rails, left hand rail for two rail installations.

Connection 2 is the motor brush wires labeled "MTR". The red and gray wires which are to be connected to the motor brushes. These wires should be connected so that when the "E" unit initially "powers on" in FORWARD the locomotive actually starts in FORWARD. When the FORWARD direction is set, the red wire is positive and the gray wire is negative.

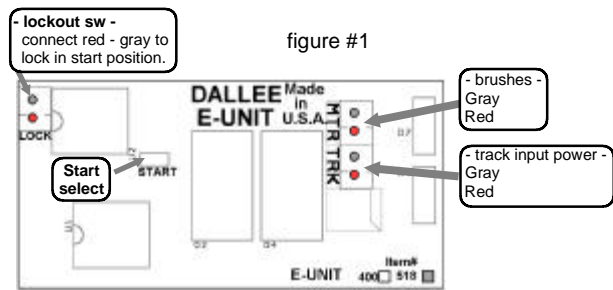

figure #1

This electronic "E" unit (0.9" by 1.95" by approx. 0.375" in height) is designed for DC motors. It will provide sequential direction control for locomotives with permanent magnet DC motors. It has a continuous duty capacity of one (1) amperes of current flow, sufficient for most newer locomotives with small motors. While most operators will use AC track power, this "E" unit will also sequence with DC track power. The initial "power on" state is user selectable so you can decide if you want the locomotive to start in either FORWARD or NEUTRAL. Provision is made so that a switch (not supplied) can be installed to lock the "E" unit in its initial state. Lock in FORWARD for automation applications or lock in NEUTRAL to allow sound systems and lights to function with a static locomotive. If power is off for approximately 6 seconds, the "E" unit will reset to its initial "power on" position. The "E" unit was also designed for easy installation of accessory items such as lighting. Remember that when lighting is controlled from the "E" unit the total current from the "E" unit includes the lighting current as well as the motor current. Using our 5 volt lamps (item #) with a 180 ohm, 1 watt, resistor in series will only draw 60 milliamps! This is far less than the 1/4 ampere that larger lamps consume. If you are looking for a simple directional lighting unit, consider our lighting units with either a white LED, item #550, or with a 5 volt lamp, item #562.

Connection 3 is a 2 pin header located at a corner of the circuit board labeled "LOCK". This permits a switch (see Item 524) to be connected to lock the "E" unit so it does not sequence. To include a lockout switch use the 2 place connector with red and gray wires. The "E" unit can be locked in either the FORWARD or NEUTRAL positions depending on the status of the lockout switch (open = sequence).

Connection 5 is a 2 pin header with a shorting connector installed. With the connector installed the "E" unit will initially "power on" in the FORWARD position. If the connector is removed, the "E" unit will initialize in the NEUTRAL position.

Smoke units SHOULD NOT BE CONNECTED to the motor brushes. Connect these units directly to track power using the red and gray wires. Various connectors and pin arrangements are available, see the DALLEE catalog or web site. If you are using this in conjunction with a LocoMatic™ sound & control system, don't forget to add a choke in series with one of the power pickup leads.

Double motored units: connect the motors in parallel or try a series connection. This will slow the locomotive down but may yield more realistic speeds. It will also reduce the current required by half! Remember, this e-unit is only rated for 2 ampere of motor current!

If you would like an e-unit with sound see the DALLEE LocoMatic™ Sound and Control systems or add sound using our DC sound system. You can use these with AC track power and a LocoMatic™ controller. See app note on our web site.

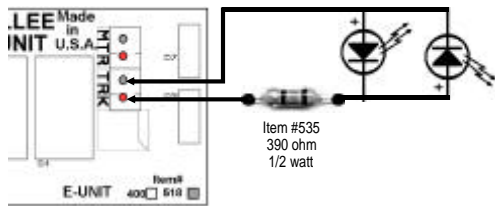

dwg #2 - using LED's with AC track power. Both are constantly ON. If only one LED is desired you do need to use a diode for the other LED.

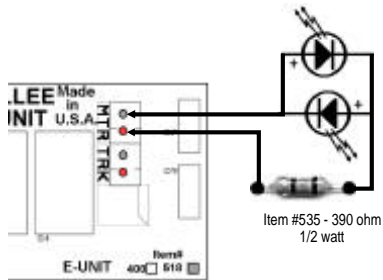

dwg #3 - directional LED's. If only one LED is desired you do need to use a diode for the other LED.

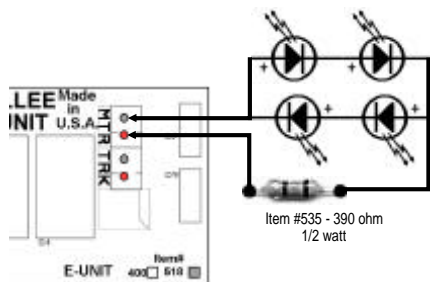

dwg #3A - two directional LED's. If only one direction pair of LED's is desired you do need to use a diode for the other LED's.

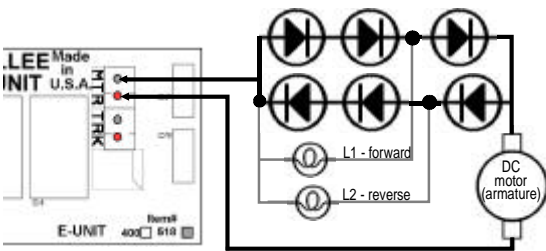

dwg #4 - 1.5 volt lamp directional headlights. The lamps MUST be insulated from the chassis. This configuration reduces the operating voltage to the motor.

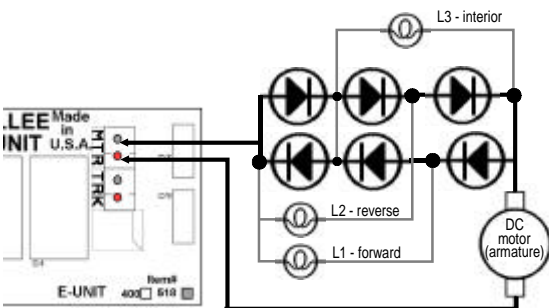

dwg #5 - 1.5 volt lamp directional headlights plus 1.5 volt constant lighting. The lamps MUST be insulated from the chassis. This configuration reduces the operating voltage to the motor.