

OPTO-DT

INFRA-RED OPTICAL DETECTION

The OPTO-DT is a detection device in which the output relay (Double Pole Double Throw) is activated when the optical path of an infra-red beam is interrupted. An additional version allows up to three separate infra-red beams activating the same relay.

The electronic circuitry must be powered by a regulated 12 volt DC supply (see our 12VPS, item 369) in order to function properly, failure to do this will destroy the electronics.

The infra-red beam is generated by an input set (optical coupler) consisting of an emitter (looks like a black LED) and a detector (looks like a clear LED). The emitter and detector are mounted on the layout so as to establish a line of sight beam across an area where detection is desired. The emitter and detector can be separated by more than 6 feet but must be precisely aligned. To assist in this alignment, there is an LED on the OPTO-DT which illuminates when proper adjustment is achieved. The version with multiple inputs has switches so that each emitter/detector set can be independently aligned. If a hood or shield is placed on the detector the range of the infra-red beam can be extended substantially. The actual distance will depend on conditions within your layout area and on how precisely you are able to align the emitter/detector set.

The OPTO-DT can be set for two distinct time functions. In NORMAL function, with the time adjustment at minimum setting, the relay will be activated (on) when the infra-red beam is interrupted and relaxed (off) when the beam is restored. As the time adjustment is increased a minimum (on) time for the relay is established. When the beam is broken the relay is (on) for at least the minimum time period. If the beam remains interrupted beyond the minimum time period the relay stays (on) until the beam is restored. In TIMER function, when the beam is broken, the relay is (on) for the duration of the time adjustment, then relaxes (off). The relay will not again activate until after the beam is restored which will allow the circuit to reset. This time adjustment is variable from momentary to about 60 seconds.

Each OPTO-DT is furnished with one input set (optical coupler). Additional sets are available for use with the multiple version which can handle up to three input sets.

OPTO-DT

[] DT1 #552

[] DT3 #553

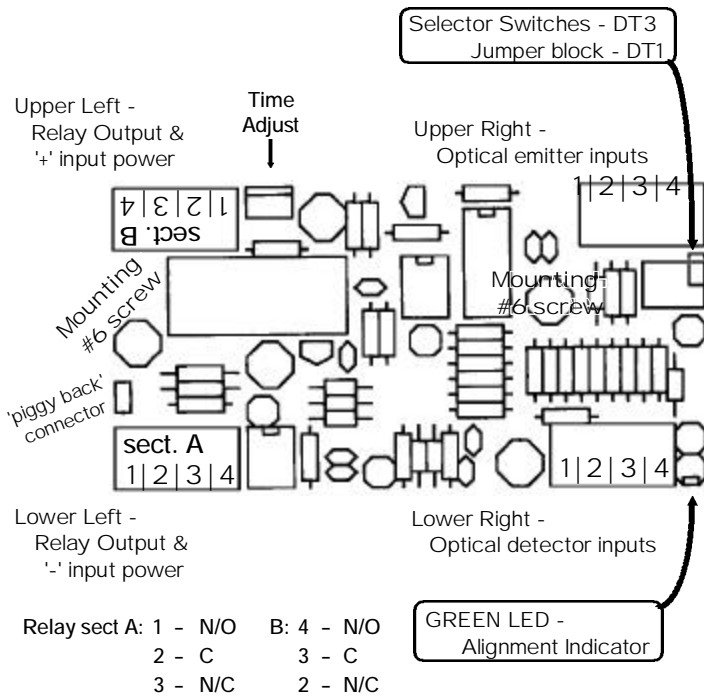

INSTALLATION & OPERATION

The OPTO-DT has two sets of terminal strips which are used when installing the OPTO-DT for operation. The first set is used for the connections to the relay contacts and the 12 volt regulated DC input power. With the relay positioned to the left of the circuit board and the green LED at the lower right corner, the connections to the left terminal strips are as follows:

Upper terminal #4 and Lower #1

Normally open contact -> when relay activates this contact is connected to the common contact

Upper terminal #3 and Lower #2

Common contact

Upper terminal #2 and Lower #3

Normally closed contact -> this contact is connected to common,
except when the relay is activated, the contact is disconnected

Upper terminal #1 : (+) connection from the 12 volt DC power

Lower terminal #4 : (-) connection from the 12 volt DC power

Note: Reverse polarity of the 12 volt DC input power or not using 12 volt regulated DC will damage the OPTO-DT and will not be warranted for consequential damage. All connections should be done with the power OFF and all wires should not be stripped longer than 1/8" so as not to allow shorting to occur to the circuit board tracks at the barrier strips on the printed circuit board

The second set of terminal strips, to the right, are used to connect the input sets (optical coupler). The lower right strip is for the detectors (clear). The copper wire of the detector connects to terminal #1 and the silver wire connects to #4. In the multiple version the copper wires from the second and third detectors connect to #2 and #3. All silver wires from the detectors connect to terminal #4.

The upper right strip is for the emitters (black). The copper wire of the emitter connects to terminal #1 and the silver wire connects to terminal #4. In the multiple version the emitters must be connected in series. The copper wire of the first emitter connects to terminal #1, silver wire connects to the copper of the second emitter (#2), whose silver then connects to the copper of the third emitter(#3). The silver wire of the last emitter always connects to terminal #4. These series connections can be made at the #2 and #3 terminals as indicated above or directly, wire to wire, at the layout location.

The emitter/detector devices are supplied, mounted on brackets, with wires attached. When attaching these brackets to the layout please use screws and care so as to minimize vibration to the devices. To extend the distance between the emitter and detector it will be necessary to lengthen the wires. When extending these wires it is absolutely essential that the polarity of the connections from the emitter/detector devices to the OPTO-DT board be maintained. If the polarity is reversed the optical devices will be damaged. It is suggested that when possible only the emitter wires be extended. If you must extend the detector wires, do so sparingly as extra wire length may reduce the sensitivity of the detector. As a further aid in extending the optical range a hood or shield can be installed on the detector. A short length of tubing, heatshrink is ideal, makes an excellent hood.

After mounting the optical devices and making all electrical connections to the OPTO-DT board it is time to power up and check the alignment of the optical path. When the alignment is correct the small green LED in the lower right corner of the board will illuminate. Alignment is accomplished mechanically by bending and rotating the mount brackets. The further apart the optical devices are mounted the more critical precise alignment becomes. Take your time and have patience.

The multiple input version of the OPTO-DT has a block of four small rocker type switches which are used to change functions. Switches #1, #2 and #3 are for selecting and aligning the optical sets. If you are using less than three optical sets with this OPTO-DT, the switch for the unused set must be in the open position. For adjustment of alignment, turn the selected switch to the closed position and leave the other two switches open. This will allow each of the optical sets to be independently selected for alignment. When alignment has been completed, return the switches for the optical sets to their closed positions which is the normal position for operation.

Rocker switch #4 is used to determine which time function is to be selected. When switch #4 is closed the NORMAL function is operational. In NORMAL function, the relay is activated when the optical path is interrupted and relaxed when the optical path is restored. There is a time adjustment potentiometer located above the relay, adjacent to upper left terminal #1. Full counter clockwise rotation of this potentiometer corresponds to minimum (momentary) time setting. Rotating clockwise will increase the time setting to a maximum of about 60 seconds. With the OPTO-DT in NORMAL function, this time setting establishes a minimum on time for the relay i.e., when the optical beam is interrupted the relay is activated for the minimum time or for the duration of the interruption, which ever is LONGER. If switch #4 is open the TIMER function is selected. In TIMER function, when the optical path is interrupted, the relay is activated for the set time period and then is relaxed. The relay WILL NOT ACTIVATE AGAIN until the optical path is restored which will allow the circuit to reset.

The OPTO-DT with only one input set has a jumper bar in place of switch #4. NORMAL is selected when the jumper is closed while an open jumper sets TIMER function. DO NOT place this jumper across the other connector!

The output relay of the OPTO-DT is of Double Pole Double Throw configuration with contacts rated at 5 Amps. There may be situations where you may desire to have additional relay contacts available. At the left edge of the OPTO-DT board, just above the lower left terminal strip, there is a two pin connector. This connector allows a second relay (Item #555) to be operated by the OPTO-DT. This 'piggy back' relay is furnished on a mounting board with terminal strips and is wired with the correct plug to make the connection to the OPTO-DT.

When power is first applied to the OPTO-DT the relay will energize for the duration of the selected time cycle.