



246 W. Main St.
Leola, PA 17540
(717) 661-7041

Hardware for holding the box together is located in a separate plastic bag. To put the box together requires placing the two halves together. Then place the four screws in each corner and tighten. Last, press the rubber feet into the holes to complete the installation.

If remote operation is required for the sound controller push buttons, merely connect the three pin plug with wires to the appropriate switches / relay contacts (do not use opto-isolators for this application) as shown in the lower half of page two. DO NOT solder to the connector pins on the pc board or any other places on the pc board! This will void any warranty and possibly prevent / create future repairs that would normally not be necessary.

OPERATING INSTRUCTIONS

The SOUND CONTROLLER's sole function is to transmit a signal to the IN LOCOMOTIVE SOUND SYSTEM to activate the whistle (horn) and / or bell sounds. Since your sound equipped locomotive can be located anywhere on your track it is required that the SOUND CONTROLLER also be connected to the track. In order for your locomotive to operate on the track, propulsion power from your power pack or throttle must also be connected to the track so it was a simple matter to establish the SOUND CONTROLLER as a pass through between the power and the track.

The SOUND CONTROLLER does not use the propulsion power coming from your power pack or throttle. In fact, even with your power pack turned "off" the SOUND CONTROLLER can transmit its activation signals. If the IN LOCOMOTIVE SOUND SYSTEM is turned "on" and the SOUND CONTROLLER is connected to the section of track where the locomotive is located, the whistle (horn) and/or bell sounds can be activated.

While the SOUND CONTROLLER does need a power source such as the 9 volt battery or external source, it only consumes power while actually transmitting its signal. The SOUND CONTROLLER is activated when any button is depressed. The correct signal is transmitted for the particular button sequence. After no buttons are depressed for a period of time, the SOUND CONTROLLER will again turn itself off. When transmitting a signal the SOUND CONTROLLER can consume up to 45 milliamps, at idle (before turning itself off) only 9 milliamps are consumed (these are typical current values).

Any load on the track such as conventionally lighted passenger cars or cabooses will have a tendency to reduce the signal strength of the SOUND CONTROLLER. If the loss is such that the sounds do not activate properly, it will be necessary to install a supplementary circuit in conjunction with the lights. This is referred to as a "CHOKE PACK" in the installation instructions of your sound system.

OPTIONS

If you are using the DALLEE ELECTRONICS TRAK-DT family of detection circuits for signalling or automation purposes and have installed the KEEP-A-LIVE system, you have already employed a pass through set up as the KEEP-A-LIVE is wired between your power pack or throttle and the track. When installing the SOUND CONTROLLER along with the KEEP-A-LIVE it is suggested that to reduce possible signal loss the KEEP-A-LIVE be connected to the power pack or throttle, then connect the SOUND CONTROLLER and then pass through to the track. In this option the track output terminals of the KEEP-A-LIVE are connected to the "CAB" input of the SOUND CONTROLLER.

DC sound controller #585

CAUTION-THIS DEVICE CAN BE DAMAGED BY STATIC DISCHARGE. PLEASE EXERCISE CARE DURING INSTALLATION TO AVOID THIS POSSIBILITY. DISCHARGE YOURSELF TO AN ELECTRICAL GROUND (OUTLET COVER SCREW) BEFORE CONNECTING WIRES. PLEASE READ INSTRUCTION SHEET COMPLETELY BEFORE ATTEMPTING TO INSTALL AND OPERATE THIS PRODUCT.

OVERVIEW

The SOUND CONTROLLER contains two push buttons to operate the WHISTLE (HORN), BELL, and other functions depending on the sound system it is operating. While the SOUND CONTROLLER, as designed, requires a 9 volt battery, an external REGULATED DC source of 9 to 12 volts, such as the DALLEE ELECTRONICS 12 VPS (Item 369), can be substituted. The SOUND CONTROLLER is designed to handle 5 amperes of continuous DC track current although it can handle higher current loads.

The SOUND CONTROLLER turns itself on when you press a button. It turns itself off after each use. Typical 9 volt batteries should last over a years time, but this does depend on how often and how long individual buttons are pressed.

INSTALLATION INSTRUCTIONS

The SOUND CONTROLLER box consists of the top portion (with the PC board mounted to it) and a bottom portion (with a hole located at the rear for wires to pass through). With the battery box portion of the box removed you will see a battery connector with red and black wires. This connects to the 9 volt battery or to an external "regulated" DC power source. When using external power be sure that the source is regulated DC, and is at least 9 volts but not more than 15 volts. The external source should be from a separate supply and NOT from the trains existing power transformer. The plus (+) is connected to the red wire, minus (-) to the black wire.

With the sound controller box in two halves, place the top half upside down. At the left of the circuit board is a four place terminal strip which provides for the connection of the SOUND CONTROLLER (refer to the top of page two for pictorial) between your existing power pack or throttle and your track. Connect two wires from the output of your power pack or throttle to the terminals labeled "CAB" (don't forget to pass these thru the hole in the bottom half of the sound controller box). The two terminals labeled "TRACK" now become the output and are to be connected to your existing layout wiring leading to the track (where the throttle connections previously were). Don't forget to pass these wires thru the hole in the bottom portion. The "+" and "-" are only for polarity reference and have no other meaning. If you reverse your wires the train will merely run in the opposite direction than it did before splicing the SOUND CONTROLLER into your track feeds.

INPUT
from CAB
(DC speed control - this is what
use to go directly to the track)

install wires by stripping insulation
back 3/16", place wire in hole, run
screw down to clamp in position.

OUTPUT
to TRACK

The "+" and "-" are only shown for polarity of
wires and have no other reference. If the "+" and
"-" of the input do not correspond to the output
then your train will operate opposite (in direction)
than what it did prior to installation of the
controller. If this happens, merely reverse the
"OUTPUT to TRACK" wires or the "INPUT from
CAB" but NOT BOTH!

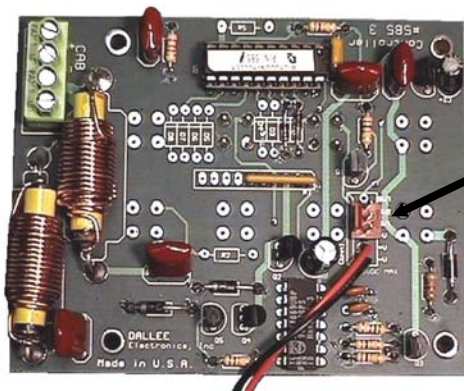
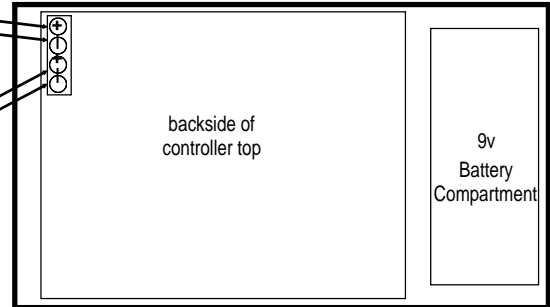

remote
switch input
connector

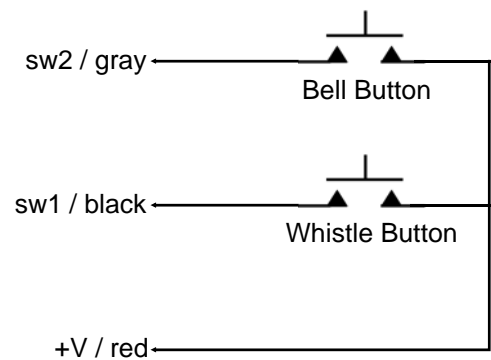

diagram for remote switch connections

Remote switches can be either momentary switches such as item #618 or relay's operated from radio controllers. If more than one location is desired around the layout, multiple switches can be placed in parallel.