

22 Watt Amplifier

Item #672

\$39.95

This amplifier was designed to be used with all Dallee Electronics Inc. sound systems and may also be adapted to other uses. The amplifier includes both Treble and Bass controls and is designed for use with 8 or 16 ohm speakers. **DO NOT USE 4 OHM SPEAKERS OR MULTIPLE SPEAKER CONFIGURATIONS EQUIVALENT TO LESS THAN 8 OHMS!** The amplifier is small enough to fit most 'G' gauge and larger type trains.

Excess heat can be generated when volume is set to high levels or with Bass set to boost so when installing this amplifier be sure to allow for adequate ventilation and do not place the heat sink too close to plastic body shells. Note: cutting Treble rather than boosting Bass results in a bass effect with less heat being generated.

Standard round speakers as supplied with Dallee Electronics sound systems are 0.5 watt or less and are not appropriate for use with this amplifier. Use our optional Oval and higher wattage round speakers or larger 8 ohm speakers instead.

The maximum DC input is 25 volts but typical operation is in the 12 to 24 volt range. If insufficient voltage is present, the amplifier will not turn on, i.e. pass any sound to the speaker. Output power is limited to that of the supply power. Inadequate supply power will hamper the amplifiers ability to perform the audio output power desired.



246 W. Main St.
Leola, PA 17540
(717) 661-7041
www.dallee.com

Utilizing External AC Supply with Power Amplifier and DC Sound Systems in a stationary application.

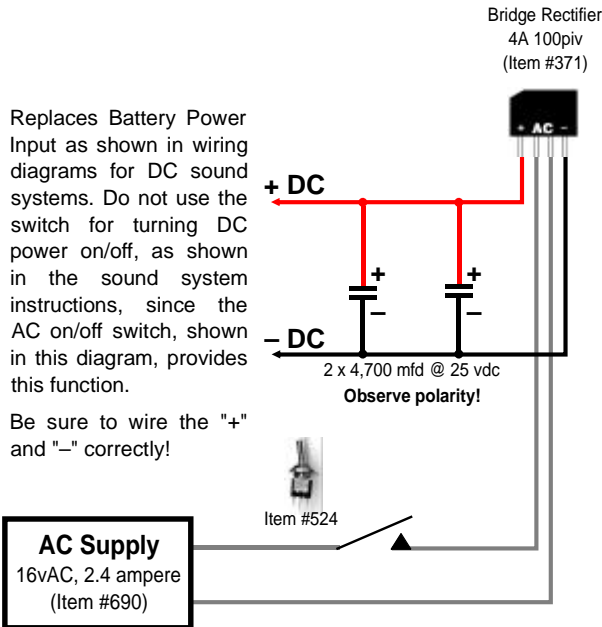

"*" denotes connection, join wires together & insulate. Otherwise wires are just passing over and do not connect.

All* extra items shown are available as Item #603 :
Audio Amplifier Accessories

These items do have to be wired (not supplied on pcbd)

*does not include the AC supply (Item #690).

Input power connections are to be connected to the DC source specified observing proper polarity. The plus is terminal #1 (red wire). The minus is terminal #2 (black wire). Audio input is terminal #3 (gray wire). None of the speaker connections should come in contact with any other connection or metal body part. The heatsink is common to the power ground and should also not come into contact with any other connection or metal body part. Improper connections will destroy the unit and void all warranty.

Refer to the sound system that you are using and follow that installation's instructions.

General installation:

Mounting screw location (3 provided).
Either mount unit with provided screw holes or use Item #388 for mounting.

Black finned item is the HEAT SINK. This is electrically common to the '-' DC input power. Avoid contact to other metals and allow adequate air passage for proper cooling.

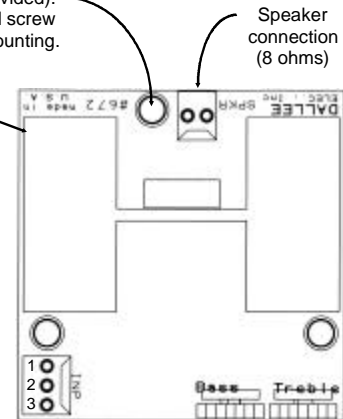

INPUT CONNECTIONS

wire connection

- 1- RED+' DC
- 2- BLACK-' DC
- 3- GRAYaudio

Using 11 or 22 Watt Amplifier with DCC or other fixed voltage track power system and Dallee Electronics DC Sound System.

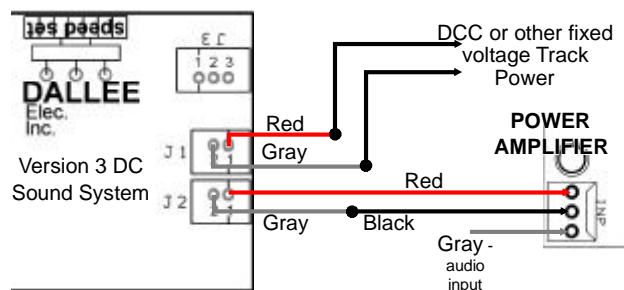

When using a single Dallee Sound system, wire the DCC track power as shown (pins 5 & 6). Wire the DC output terminals (pins 3 & 4) to the amplifier. Do NOT get the polarity reversed to the amplifier! That would destroy it and is not covered under any warranty!

All functions, motor inputs, audio input get wired as before, shown in the sound systems instructions.

When using a dual system, only wire one of the sound system to the track power (J1) input. Wire the other sound system to operate from the DC (J2) power as shown for the amplifier above.

Utilizing Fixed DC or AC track power to provide the Power Amplifier and DC Sound System power in lieu of batteries in an on board application with receiver operating from track power.

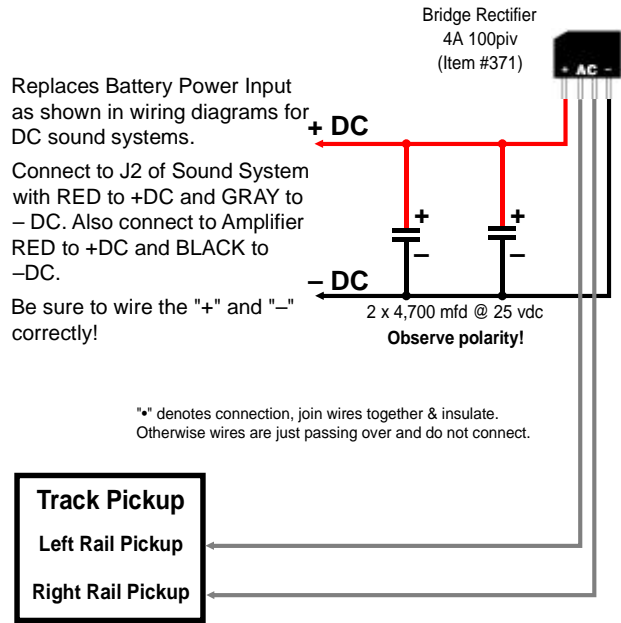

Replaces Battery Power Input as shown in wiring diagrams for DC sound systems.

Connect to J2 of Sound System with RED to +DC and GRAY to -DC. Also connect to Amplifier RED to +DC and BLACK to -DC.

Be sure to wire the "+" and "-" correctly!

"*" denotes connection, join wires together & insulate. Otherwise wires are just passing over and do not connect.

Capacitors shown are not necessary when using filtered DC track power. If unfiltered DC, only one may be necessary. Static in the amplifier will be the clue for more capacitance. It never hurts to have the capacitors in place for more filtering of the DC track power in the locomotive.

Utilizing Fixed DC or AC track power to provide the Power Amplifier power in lieu of batteries with a LocoMatic™ System instead of drawing power from the main LocoMatic™ Sound unit as shown below.

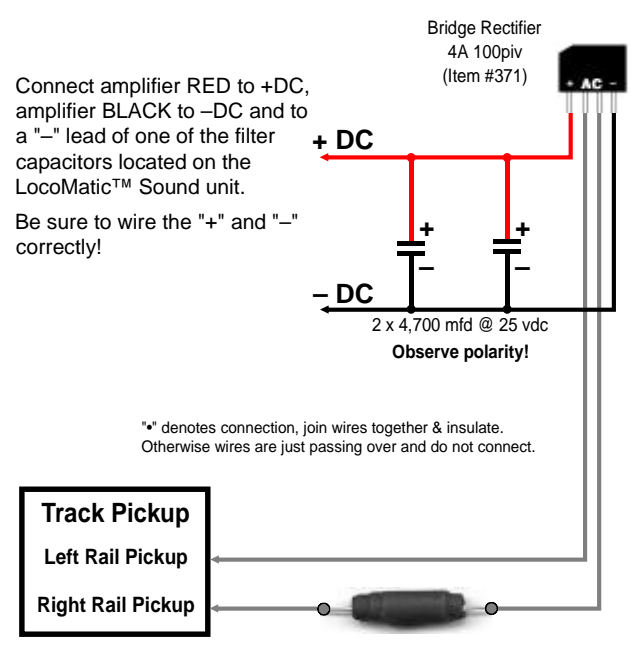

Connect amplifier RED to +DC, amplifier BLACK to -DC and to a "-" lead of one of the filter capacitors located on the LocoMatic™ Sound unit.

Be sure to wire the "+" and "-" correctly!

"*" denotes connection, join wires together & insulate. Otherwise wires are just passing over and do not connect.

Place a choke in series with the right rail pickup.

Item #702 will be sufficient. This choke is necessary when operating with the LocoMatic™ system. Failure to do so will result in unrecognized or intermittent button operation.

LocoMatic™ Sound & Control Systems:

Connect the LocoMatic™ Sound & Control Systems as per instructions provided with the sound system. The only exception would be the speaker connections and power connections for the external amplifier. When connecting the audio amplifier to a LocoMatic™ Sound & Control System, it is necessary to solder the red and black wires to the top board's main filtered DC source. The polarity of these wires is extremely important and if not followed will damage the amplifier. The red wire needs to be soldered to the "+" of one of the 4700 mfd capacitors. The black wire needs to be soldered to the "-" of the capacitor. This is illustrated below. When connecting the audio amplifier's speaker output you can either connect both leads to another speaker and then one lead to the amplifier or you can just connect one lead to the amplifier. Which lead is not important. The other, unused lead, should be protected with electrical tape or cut off at the connector. The volume is controlled from the standard volume control but remember to abide by the precautions for total volume, bass, and treble settings.

The LocoMatic™ Sound & Control System can also be used in a stationary application. To operate this way do not connect the motor leads to any motor. Just connect the input power to a power transformer or track leads. The mode of operation can still be selected via power interruptions for sequencing or by the LocoMatic™ controller. All modes of operation via track power horn / bell operation will work as though the unit has been installed in a locomotive. Better yet, when using the LocoMatic™ controller, fixed voltage can be applied and notch / rpm settings can be set with the mere push of a button.

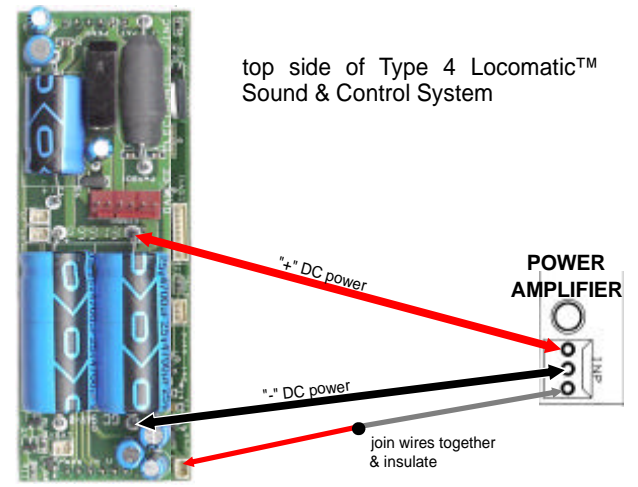

top side of Type 4 Locomatic™ Sound & Control System