

Piko #3540 R/C receiver wiring diagrams to Dallee HiLine™ Sound systems.

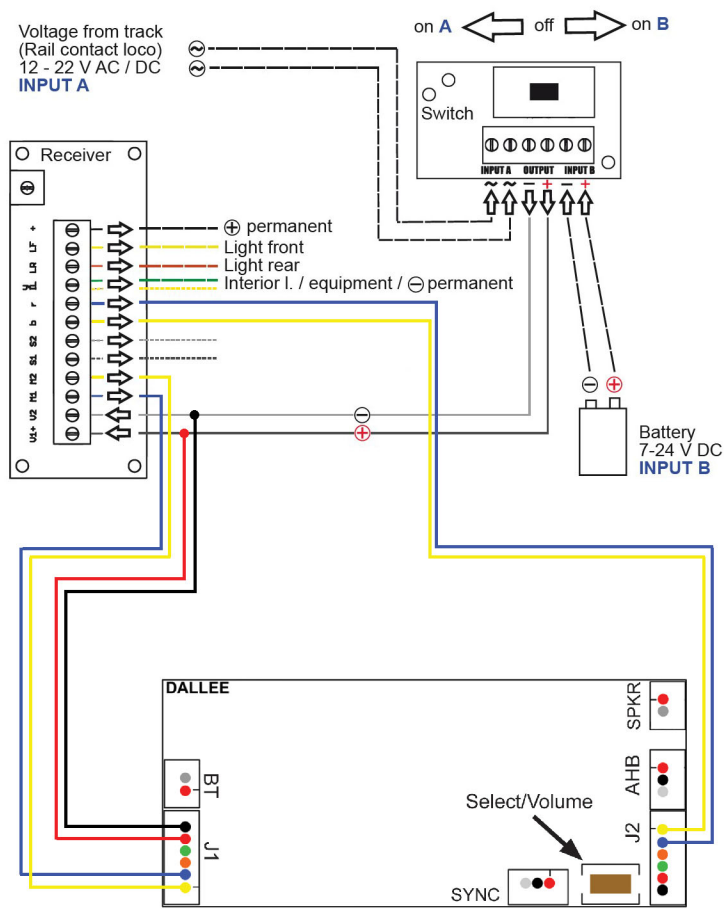

HiLine™ - Full Featured Sound System

Steam system with a synchronized chuff option
do not need to connect the J1 Yellow and Blue wires!

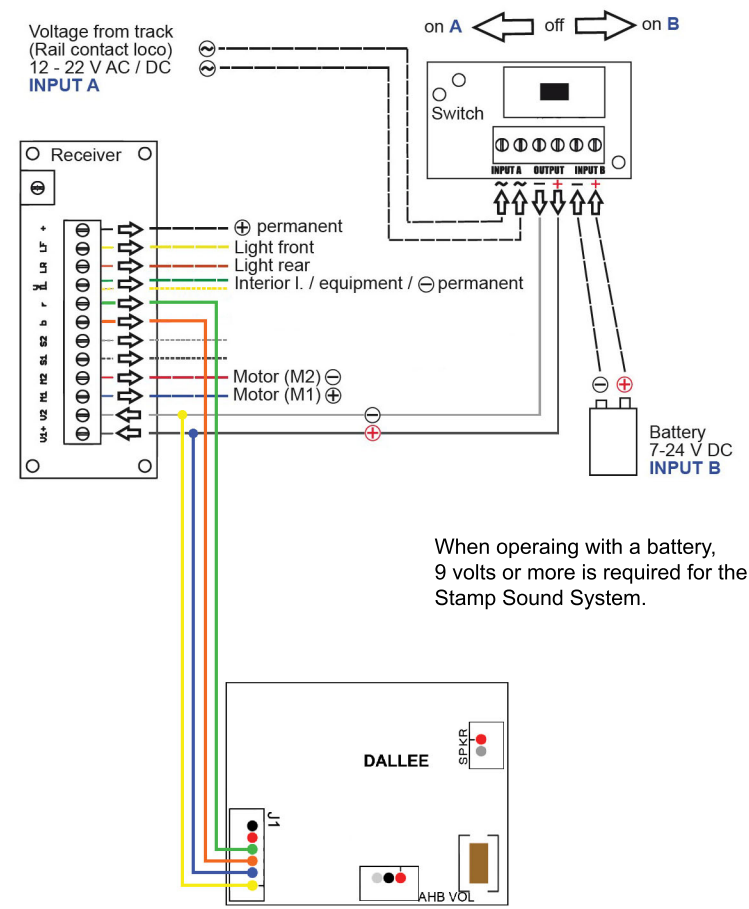

HiLine™ - Stamp Sound System

When operating with a battery,
9 volts or more is required for the
Stamp Sound System.

Both systems require the speaker to be connected to the "SPKR" connector.
The Horn/Whistle will play as long as the "J" key fob button is pressed and held.
The Bell sound will start upon first pressing the "||" key fob button. The second press will turn the Bell off.
All other remote items, such as Item Number: #1590, HiLine™ Remote (External) Select/Volume Switch can be wired in as per Sound System's instructions.