

MP54 SOUND

for various uses by



DCv3 rev0

CAUTION: THIS DEVICE CAN BE DAMAGED BY STATIC DISCHARGE. PLEASE EXERCISE CARE DURING INSTALLATION TO AVOID THIS POSSIBILITY. DISCHARGE YOURSELF TO AN ELECTRICAL GROUND (OUTLET COVER SCREW) BEFORE REMOVING THIS DEVICE FROM ITS ANTI-STATIC BAG. PLEASE READ INSTRUCTION SHEET COMPLETELY BEFORE ATTEMPTING TO INSTALL AND OPERATE THIS PRODUCT.

Save the anti-static bag for possible reuse of storing or shipping the sound unit!

OVERVIEW: This device is an electronic, self contained, sound system for installation in model trollies that are designed to operate with conventional DC track power, digital (DCC) or other types of command control systems including radio with either track or battery power, also as a stationary sound unit. Because of its dimensions (2.7" x 0.9" x approx. 0.5" high) the sound system may be limited to installations in some powered units making the need for use of a "dummy" unit or a trailing car. An alternative installation under the layout is also possible including the use of our TRAK-DT devices to switch the sound through multiple speakers so as to follow the movement of the MP54. A drawing for this application is in our Model Railroaders Wiring Guide.

An on/off switch (not included) must be used to power the sound unit on and off in some applications. The audio amplifier can produce 1.1 watts of power which is in excess of what most small speakers can handle. The speaker impedance must be 8 ohms or higher. Sound volume is adjustable. Refer to our catalog for available speakers. It is always advisable to use the largest speaker possible. See our web site or catalog for choices available.

Sounds produced include horn, bell, air compressor, and rail traveling sound.

This sound system, when used with conventional DC track power, requires the use of our LocoMatic™ Controller (Item 755) to operate the horn and bell. Traveling and door operating sounds are normally hard wired but can be wired to a DCC and other command control remote functions on their systems to activate the same functions. For stationary installations, these functions can be accessed by switches. Radio control with fixed track power or on board batteries would be similar to DCC installations and large gauge (where you ride the locomotive) would be similar to a stationary installation.

INSTALLATION INSTRUCTIONS: The sound system consists of a printed circuit board, five 2-pin connectors with wires and one 3-pin connector with wires. A CHOKE (item 702 or 703 depending on motor or load power requirements), not included, is required for DC track power installations when manual horn and bell are desired with use of the LocoMatic™ Controller. Since one size doesn't fit all, speakers are not included.

Refer to the drawing on page 2 to familiarize yourself with the connectors and controls on the sound board. Then refer to the specific instruction sheets for the type of installation you intend to make. Before proceeding with the installation read the balance of the instructions carefully so you will be completely familiar with what is required and what sounds you should hear.

The circuit board should be mounted so that at minimum, the volume control is accessible either through the frame or via a hatch or a hole in the locomotive body shell. Be certain that the components on the circuit board do not come in contact with any metal objects as such contact can destroy the sound system. The speaker should be mounted as per available space bearing in mind that sound reproduction is enhanced when a speaker is properly enclosed and baffled.

If a DC MP54 is not moving, there is no track power, therefore to have sound it is necessary to have a separate power supply for the sound system. For in locomotive use, this separate supply is a battery. We suggest the use of one 9 volt or 6 AA or 6 AAA batteries in series to maximize volume potential and battery life. Rechargeable batteries can be used. When connecting the battery (DC) power leads be absolutely certain that wires connect to the proper DC input leads. Item #996 contains all of the components with a 9v (8.4v) NiMH battery.

If any connections are not done properly, especially the power connections, you will damage the sound system. This type of damage is not covered under any warranty. The sound system is thoroughly tested and inspected before packing to insure proper function. There is a minimum charge of \$40.00 plus s/h for repair.

SOUND INFORMATION:

HORN: sound is controlled by the HORN button on the LocoMatic™ Controller, by a momentary push button or by remote function, dependent upon the type of installation. The HORN will sound as long you are holding the control on. This will allow you to actually play the sound the way you want to. DCC and similar systems will have a sound delay equivalent to system response time.

BELL: sound is controlled by the BELL button on the LocoMatic™ Controller, by a toggle switch or by remote function, dependent upon the type of installation. When BELL sound is only activated when sitting at rest. It operates the BELL in a slow fashion to represent the motor man activating it. With the LocoMatic™ Controller you depress and release the BELL button to turn on the BELL and then again depress and release the button to turn the BELL off. Toggle switch or remote function control does not require the PUSH ON - PUSH OFF sequence. The BELL will automatically turn off if the MP54 starts to move. The bell sound may have a delay until it starts to ring after activation.

TRAVELING: sounds range from no sound when stopped to full speed based upon motor voltage present (J3) and the "Notch" control setting. The traveling sounds default to sectional rail. You can select welded rail by merely connecting J5, pin 1 (red wire) to the ground connection (J2, pin 2, gray). With our LocoMatic™ Controller (#755), activating the ALT and F3 buttons simultaneously (and then releasing) will direct the sound system to alternate between welded and unwelded rail. This can also be connected to a latching function of a DCC decoder or Radio receiver.

AIR COMPRESSOR: sound is produced at random.

SPEAKER MOUNTING: The speaker generally should be mounted so that the sound can actually "get out" of the locomotive. A hole in the floor or fuel tank is acceptable but open grills or a doorway may be a better choice as the sound can exit upward rather than down toward the track. In some cases, particularly with plastic body shells, just mounting the speaker against the shell will be adequate as the vibrations of the shell can enhance the sound. Enclosing the speaker in a chamber will also enhance sound reproduction. A very simple enclosure can be made with a tube. The longer the tube, the better the speaker will reproduce low frequency sound which is inherent in diesel prime movers. It is usually best to seal the tube so there are no air passages to the rear of the speaker, thus creating a sound chamber. By carefully sealing all openings it may be possible to use the entire body shell as a sound chamber. A simple wall behind the speaker may be all that is possible or perhaps all that is needed.

Speakers can be attached with double sided tape, glue or with "hot melt". Enclosures can be made with plastic, wood, card stock or even metal. Film cans or medicine bottles make excellent sound chamber enclosures for small diameter speakers. Stiff items are best and total encasement of the speaker to the baffle is desirable.

A second speaker, wired in series with the main speaker, can also enhance sound quality and will permit a higher volume without damage to the individual speakers. A tube with a speaker at each end or a speaker in a doorway at each end of a body shell is an excellent approach. A four speaker approach will yield the highest volume while still maintaining the 8 ohm minimum requirement. Drawings for this are included in the speaker instructions.

Speaker enclosure is an art and experimentation is definitely in order for your installation so as to gain the maximum benefit of the superb sound quality available in this sound system.

GENERAL OPERATING INFORMATION:

VOLUME ADJUSTMENT: should be set as desired for your application. Please remember that the amplifier can produce more power than a small speaker can handle and that the sound will be louder if the speaker is properly enclosed and baffled. If you are using batteries, the louder the volume the shorter the battery life.

NOTCH ADJUSTMENT: full clockwise will yield full speed traveling sounds at approximately 8 volts to the track / motor. Rotate the control CCW to increase the voltage required to reach full traveling sound speed. Gauge 1 and other operators using higher motor voltages will probably want to set this control full CCW.

Troubleshooting: When operating via a receiver, if the Horn plays continuously unless you select that function, then you need to invert the signal. Drawings for this can be found on our web site under product instruction sheets.

Remember, most everything in this MP54 sound unit is automatic. The Horn and manual play of the bell are not. If neither of these are required and you want sectional rail sounds, then you don't have to connect anything to J4 or J5 since this is the default playing mode of this sound unit.

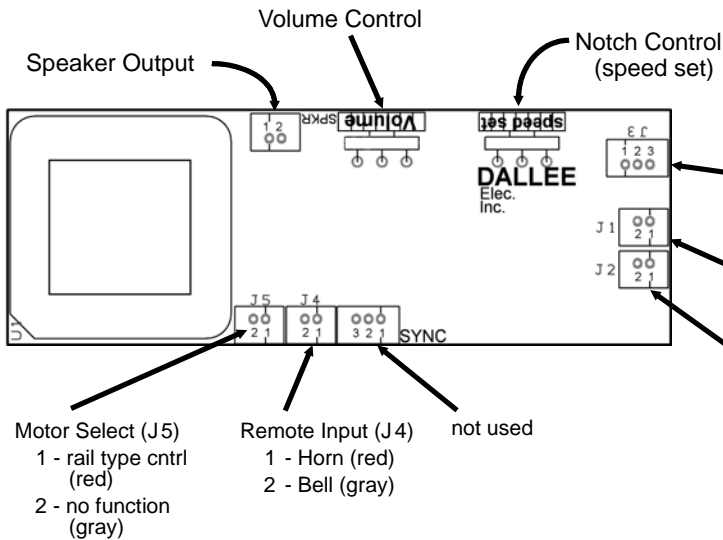

This system features an optically coupled motor input sensor. This means that any connection to J3 pins 1, 2, and 3, do not electrically connect to any other power to the board!

- J3 connections:
- 1 - track RF input (RED)
 - 2 - Motor 1 (BLACK)
 - 3 - Motor 2 (WHITE)

- J1 connections:
- 1 - DCC rail 1also AC input 1.....(RED)
 - 2 - DCC rail 2.....also AC input 2.....(GRAY)

- J2 connections:
- 1 - DC power "+" (RED)
 - 2 - DC power "-" (GRAY)

- J5 connections:
- 1 - rail type cntrl (red)
 - 2 - no function (gray)
- J4 connections:
- 1 - Horn (red)
 - 2 - Bell (gray)
- not used

SPECIFIC INSTRUCTION SHEETS	
PAGE	INSTALLATION TYPE
3 - 6.....	Conventional DC
7.....	Stationary Sound
8.....	DCC receiver
9.....	OTHER receiver
10.....	AristoCraft Revolution Installation

Other wiring / application notes can be found on our web site under "Current Product Instruction Index" then "Sound Related, misc".

NOTE: The speaker impedance should be kept near or above 8 ohms, therefore four 8 ohm speakers in a series/parallel configuration is acceptable since it yields 8 ohms total impedance. If you care to use two 8 ohm speakers you **must** place them in **SERIES**.

DO NOT touch the speaker wires to anything else, this will damage the amplifier which is not covered under warranty!

When connecting DC power to the sound unit be absolutely sure that the "+" and "-" are connect correctly! If not, you will either burn out the sound unit or the supply feeding it. This is not covered under warranty!



246 W. Main St.
Leola, PA 17540
(717) 661-7041
www.dallee.com

DC track power installation using standard batteries & DALLEE controller #755

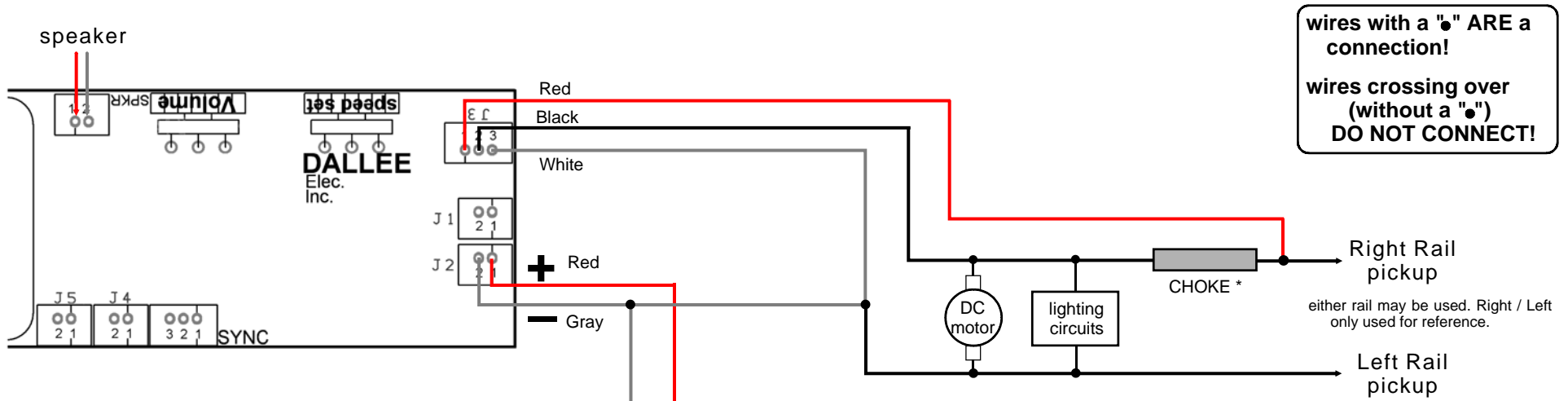

wires with a "•" ARE a connection!
wires crossing over (without a "•") DO NOT CONNECT!

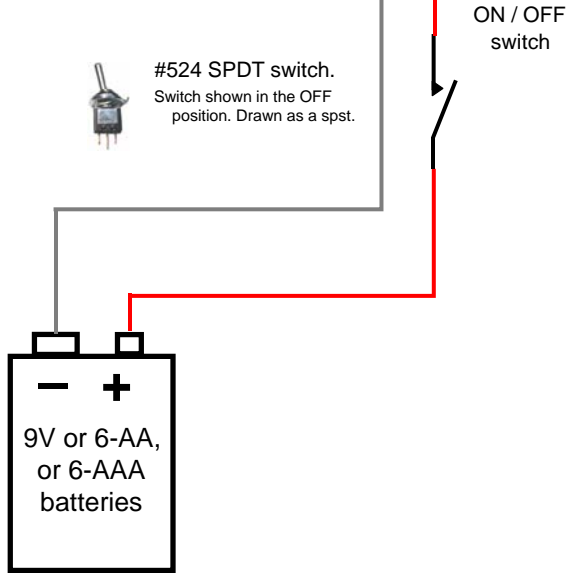

Item 996 includes 8.4v battery & recharge parts.
*Larger motors require a larger capacity choke.
Chokes:
Item 702 - 1.5 ampere loads
Item 703 - 5.0 ampere loads

Battery power - must not exceed 24 volts DC. Use one 9 volt battery or a string of 6 AA or AAA batteries (24 volt DC maximum input). Life depends on volume setting and speaker impedance. Typical operation of most sound systems for one good 9 volt batteries is about 8 hours, AA or larger is well beyond 50 hours!

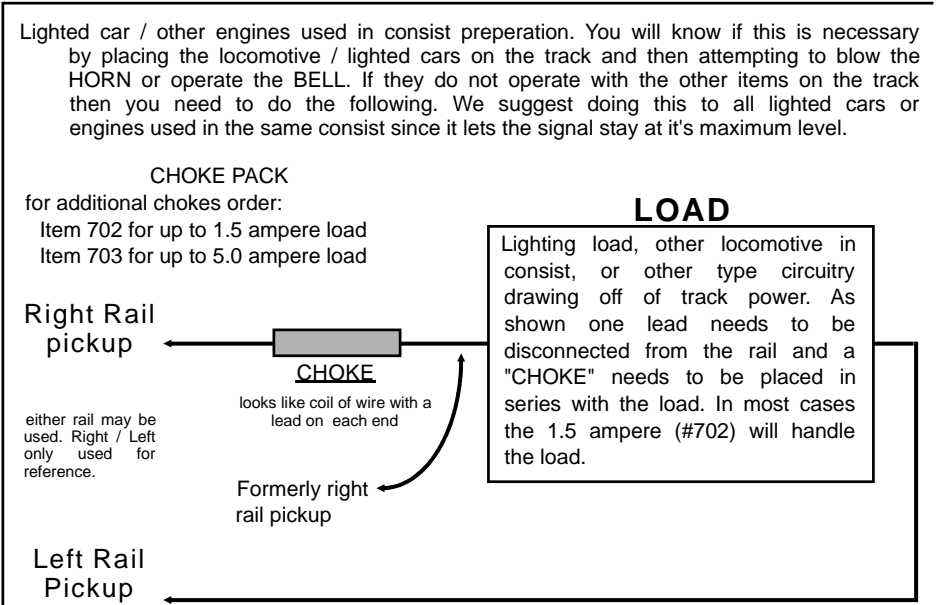

DC track power installation using standard batteries & no DALLEE controller #755

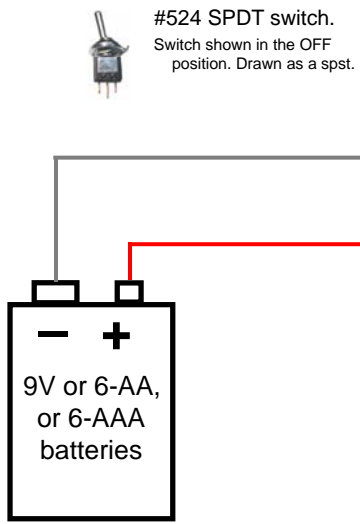
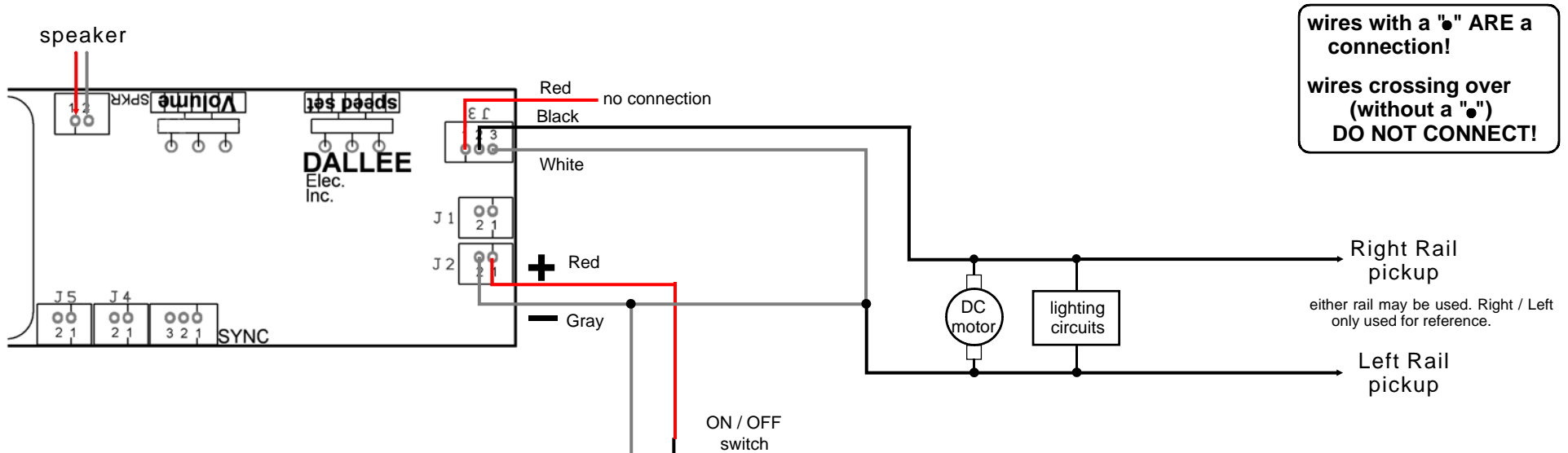

Battery power - must not exceed 24 volts DC. Use one 9 volt battery or a string of 6 AA or AAA batteries (24 volt DC maximum input). Life depends on volume setting and speaker impedance. Typical operation of most sound systems for one good 9 volt batteries is about 8 hours, AA or larger is well beyond 50 hours!

Options wiring help:

Connect all other connectors as shown. If you want to change the default play of the Sectional Rail and/or Door Sounds, add connections as shown below.

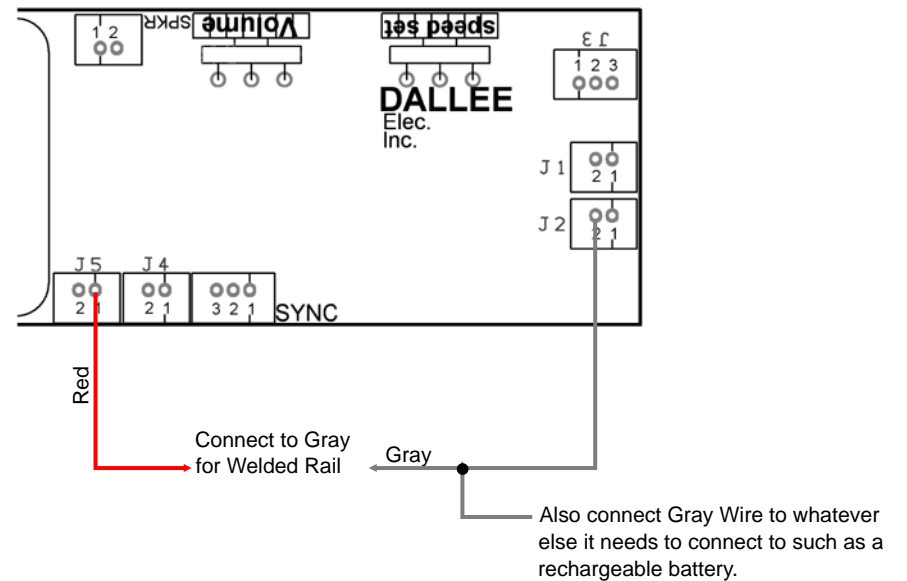

DC track power installation #2 with DALLEE controller #755.

With rechargeable or standard battery.

When track voltage exceeds battery voltage, the sound system will operate from track voltage instead of battery voltage.

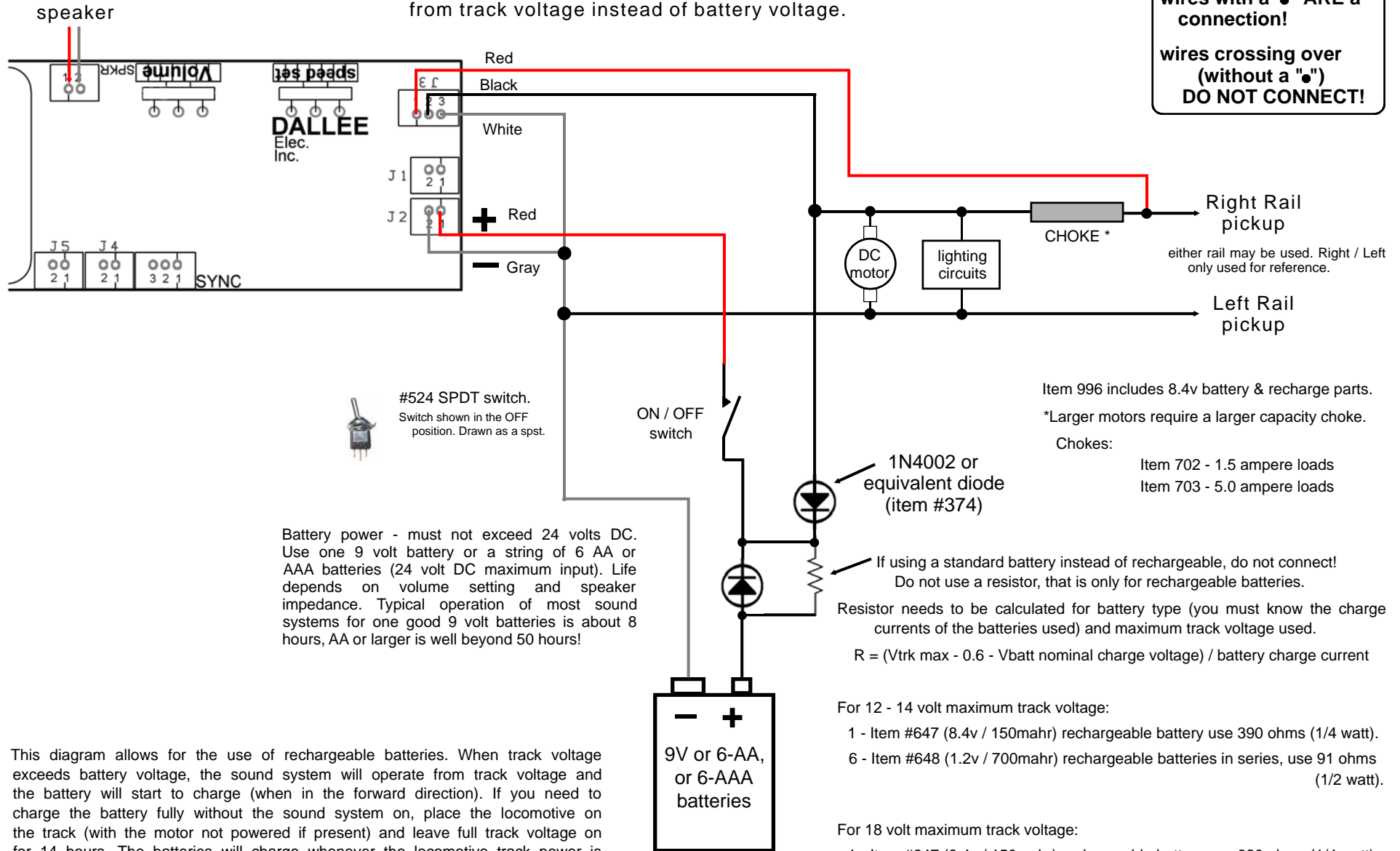

wires with a "•" ARE a connection!
wires crossing over (without a "•") DO NOT CONNECT!

Battery power - must not exceed 24 volts DC. Use one 9 volt battery or a string of 6 AA or AAA batteries (24 volt DC maximum input). Life depends on volume setting and speaker impedance. Typical operation of most sound systems for one good 9 volt batteries is about 8 hours, AA or larger is well beyond 50 hours!

Item 996 includes 8.4v battery & recharge parts.
 *Larger motors require a larger capacity choke.
 Chokes:
 Item 702 - 1.5 ampere loads
 Item 703 - 5.0 ampere loads

If using a standard battery instead of rechargeable, do not connect! Do not use a resistor, that is only for rechargeable batteries.
 Resistor needs to be calculated for battery type (you must know the charge currents of the batteries used) and maximum track voltage used.
 $R = (V_{trk\ max} - 0.6 - V_{batt\ nominal\ charge\ voltage}) / \text{battery charge current}$

For 12 - 14 volt maximum track voltage:
 1 - Item #647 (8.4v / 150mah) rechargeable battery use 390 ohms (1/4 watt).
 6 - Item #648 (1.2v / 700mah) rechargeable batteries in series, use 91 ohms (1/2 watt).

For 18 volt maximum track voltage:
 1 - Item #647 (8.4v / 150mah) rechargeable battery use 620 ohms (1/4 watt).
 6 - Item #648 (1.2v / 700mah) rechargeable batteries in series, use 150 ohms (1 watt).

This diagram allows for the use of rechargeable batteries. When track voltage exceeds battery voltage, the sound system will operate from track voltage and the battery will start to charge (when in the forward direction). If you need to charge the battery fully without the sound system on, place the locomotive on the track (with the motor not powered if present) and leave full track voltage on for 14 hours. The batteries will charge whenever the locomotive track power is set for the forward condition regardless of the sound system being on or off. They will not charge when the polarity on the track is set in reverse. When running in reverse, the sound system will only operate from the battery. A bridge rectifier could be used instead of a single diode alleviating this potential problem.

DC track power installation #4 - no controller, standard track power and rechargeable or standard battery.

When track voltage exceeds battery voltage, the sound system will operate from track voltage instead of battery voltage.

wires with a "•" ARE a connection!
wires crossing over (without a "•") DO NOT CONNECT!

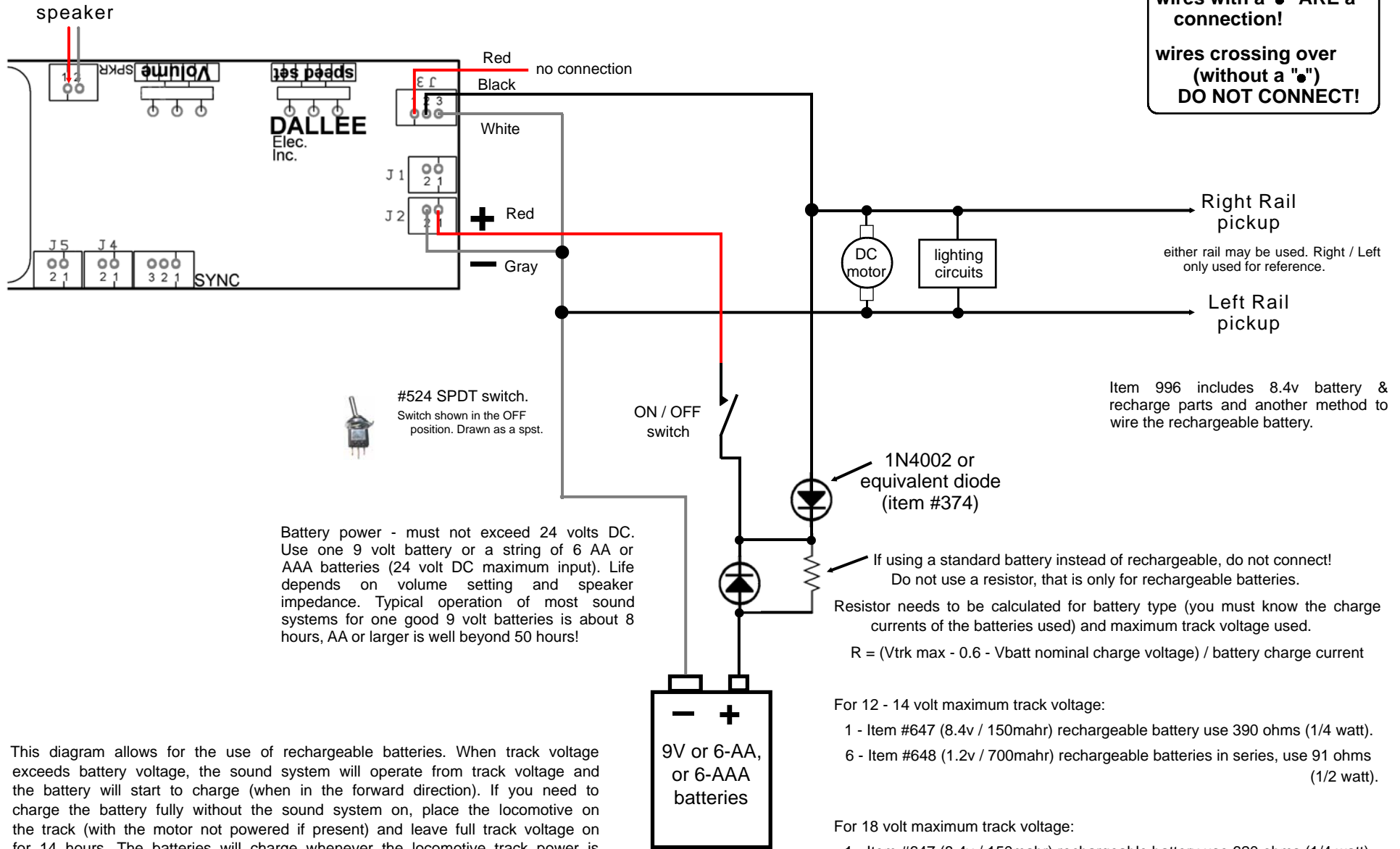

Battery power - must not exceed 24 volts DC. Use one 9 volt battery or a string of 6 AA or AAA batteries (24 volt DC maximum input). Life depends on volume setting and speaker impedance. Typical operation of most sound systems for one good 9 volt batteries is about 8 hours, AA or larger is well beyond 50 hours!

This diagram allows for the use of rechargeable batteries. When track voltage exceeds battery voltage, the sound system will operate from track voltage and the battery will start to charge (when in the forward direction). If you need to charge the battery fully without the sound system on, place the locomotive on the track (with the motor not powered if present) and leave full track voltage on for 14 hours. The batteries will charge whenever the locomotive track power is set for the forward condition regardless of the sound system being on or off. They will not charge when the polarity on the track is set in reverse. When running in reverse, the sound system will only operate from the battery. A bridge rectifier could be used instead of a single diode alleviating this potential problem.

For 12 - 14 volt maximum track voltage:

- 1 - Item #647 (8.4v / 150mah) rechargeable battery use 390 ohms (1/4 watt).
- 6 - Item #648 (1.2v / 700mah) rechargeable batteries in series, use 91 ohms (1/2 watt).

For 18 volt maximum track voltage:

- 1 - Item #647 (8.4v / 150mah) rechargeable battery use 620 ohms (1/4 watt).
- 6 - Item #648 (1.2v / 700mah) rechargeable batteries in series, use 150 ohms (1 watt).

Stationary DC power installation using track power for notch setting.

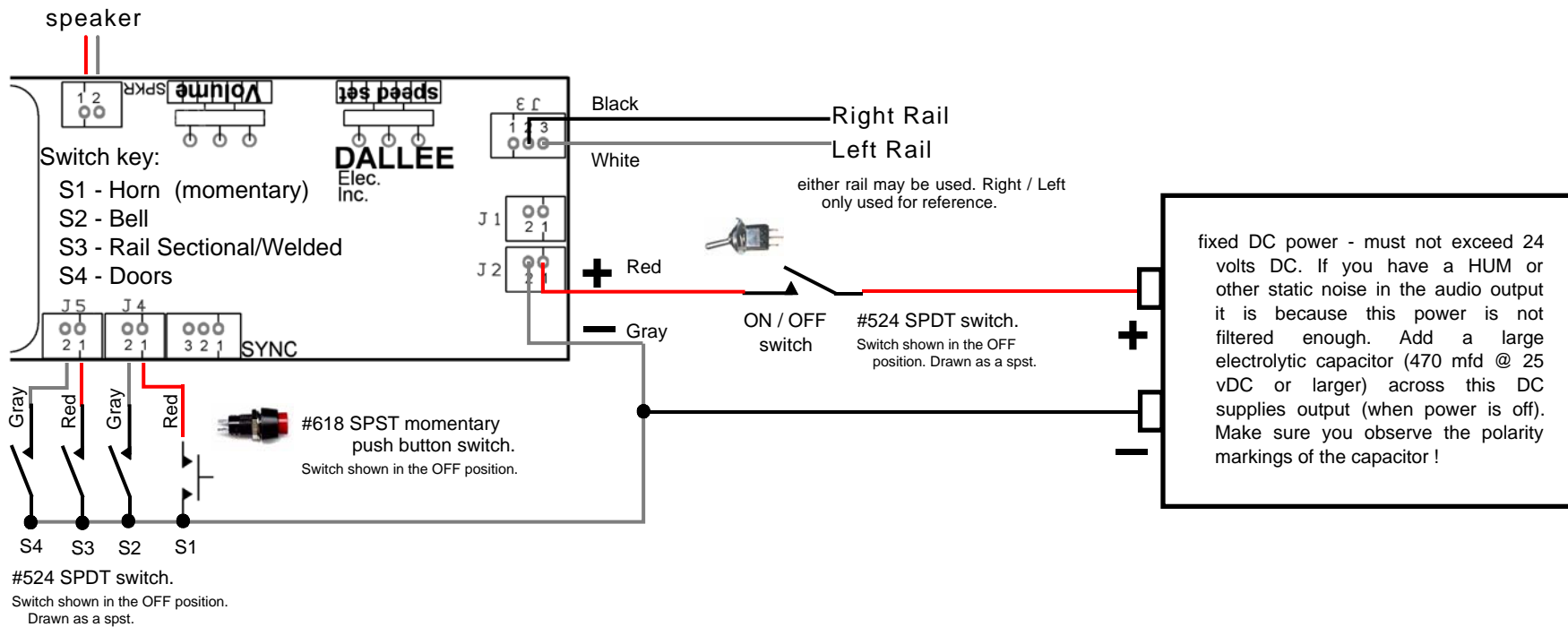

Stationary AC power installation using track power for notch setting.

